



*The* Industry Leader in Dust Collection

# OWNER'S MANUAL



**High Vacuum  
Dust Collector  
with SMART Boost**

5 HP

# XXS050333

U.S. Patent: #8491685,  
#8514090, #8496719,  
#7247180



**Intertek**



# Table of Contents

---

**System Start-Up Information**.....2

**System Specifications**.....4

**System Dimensions**.....5

**System Contents**.....6

**Assembly Instructions**.....8

**Maintenance**.....20

**Troubleshooting**.....21

**F.A.Q.**.....22

**Recommended Accessories**.....24

**Warranty Information**.....26

**Notes**.....27

# System Start-Up Information



**Make sure to read and understand the installation and maintenance instructions as well as all recommended safety practices.**

## **⚠ WARNING ⚠**

1. Install ductwork completely before operating collector
  - a. Seal ductwork with silicone sealant or duct tape.
  - b. Have dust drum in place and sealed.
2. DO NOT operate Fan / Blower unless Fan Housing is attached to Cyclone body and Dust Drum is in place. Dust Drum and Cyclone must be in place and sealed or motor will overheat!
3. DO NOT operate without filter in place. Fan blade can cause serious injury.
4. The Direct Drive Fan / Blower makes the system top heavy! Use extreme care when setting the unit up! It is recommended that at least two people lift the system up.
5. Check amperage draw on motor with all gates open. Current draw should not exceed maximum motor amperage as stated on motor plate. (Oneida Air Systems is not responsible for damage to motors caused by improper installation, wiring or failure to follow these directions).
6. This equipment incorporates parts such as switches, motors or the like that tend to produce arcs or sparks that can cause an explosion.
7. To reduce the risk of Electric Shock, DO NOT use outdoors or on wet surfaces.
8. Exhaust air should not be vented into a wall, a ceiling, or a concealed space of a building.
9. To reduce the risk of injury from moving parts - unplug BEFORE servicing.

## **⚠ FIRE HAZARDS ⚠**

1. Wood shaping and cutting processes generate wood chips, shavings and dust. These materials are considered combustible. Air borne wood dust below 420 microns in size (0.17 of an inch) in certain concentration ranges when ignited can deflagrate (burn quickly). An ignition source such as a spark or ember can ignite a dust mixture resulting in an expanding flame front, which can cause an explosion if tightly contained. A disturbance that raises a cloud of accumulated fine dust can raise additional dust clouds, which can cause a series of explosions that can level an entire building. Until this type of fire has been witnessed, it is difficult to believe the devastation. This type of fire is rare but worth safeguarding against.
2. The best way to avoid a wood shop fire is to keep the shop clean. A shop ankle deep in dust with layers of fine dust everywhere is an accident waiting to happen. A good dust collection system reduces overall fire hazards but also adds new concerns. A fire hazard is still present. Combustible material is now in the dust collector and storage container.
3. The following points are worth heeding:
  - a. It is the buyer's responsibility to follow all applicable federal, state, local, OSHA, NFPA, or authorities having jurisdiction codes and regulations when installing and operating this dust collector.
  - b. Fire Marshals may want the unit located outside of the building. If the collector is located inside the facility, controls such as spark detection, suppression, or explosion venting may be required.
  - c. Most local jurisdictions consult or adopt NFPA (National Fire Protection Agency) codes. However, other codes may apply. Local codes may vary from jurisdiction to jurisdiction.

# System Start-Up Information (Continued)

---

- d. NFPA664 Code book, “Standard for the Prevention of Fires and Explosions in Wood Processing and Woodworking Facilities”, applies to woodworking operations that occupy areas of more than 5,000 sq. ft. or to areas where dust producing equipment requires an aggregate dust collection flow rate of more than 1,500 cfm (cubic feet per minute). This exempts some small operators from the NFPA code 664, but other codes may apply in your jurisdiction. Consult your local Fire Marshal for help. Additional information can be found in NFPA Code Book 664.
4. The customer assumes the responsibility for contacting their insurance underwriter regarding specific application requirements of explosion venting or if additional fire protection and safety equipment may be required.
5. DO NOT use this product to collect other types of flammable dust or flammable vapors! - Fire or explosion may occur!
6. NEVER collect sparks from a bench grinder into a wood dust collector.
7. NEVER introduce sparks or sources of ignition into the dust collector.
8. Personnel should be kept at least 20 ft. away from unit.
9. Check dust bin frequently and before leaving the shop for smoldering material.
10. Keep portable fire extinguishers handy.
  - a. The ABC type (dry chemical) is generally a good choice for small wood shops.
  - b. Additional information on portable extinguishers can be found in NFPA 10 (Standard for Portable Fire Extinguishers).
11. Be especially careful with sanding units. They can produce concentrations of dust in the combustible range. Make certain enough air volume is at the suction point to capture all the particulate generated.
12. This high air volume will dilute the mixture below the lower limit of flammability. Be careful not to generate sparks into the sanding dust.
13. Empty dust bin and clean filter often, especially when sanding.
14. DO NOT overload woodworking equipment, especially sanders. Excessive frictional heat can spontaneously ignite dust.
15. Sparks can be generated in several ways:
  - a. High speed sanders and abrasive planers may strike foreign material.
  - b. Saws and edgers may strike foreign material and create a red-hot metal fragment.
  - c. Knots in hardwood can create frictional sparks.
  - d. Trapped metal when drawn into the collector can spark against ductwork.
  - e. Check wood stock for old nails and screws which can create red hot metal fragments.
16. Avoid using excessively large wood waste bins.
17. ALWAYS check storage bins for smoldering material before leaving for the day.
18. Electrically ground all equipment and ducting. Static sparks can ignite wood dust. (Avoid using PVC drain pipe.)
19. DO NOT allow accumulation of layers of fine dust on horizontal surfaces (especially overhead lights, electrical boxes and fuse panels which can ignite dust.)
20. UNPLUG UNIT BEFORE SERVICING OR CLEANING

**Customer Service Dept.**

**1-866-387-8822 • support@oneida-air.com**

# System Specifications

<b>OPERATION</b>	
Fan Rating (with Cyclone & Filter)	1,789 Actual CFM at 5.4" S.P.
Maximum Suction Rating	23" WC
<b>MOTOR AND ELECTRICAL</b>	
Motor Type	U.S. Made TEFC Motor
Motor Insulation	Class F
Motor Service Factor	1.15
Horsepower	5 HP
Motor Speed	3,500-4,500 RPM
Phase	Single-Phase (1ph)
Voltage	208-230V
Cycle	60Hz
Listed FLA	12-11.8A
On/Off Switch	Remote Starter with Push button On/Off Switch and RF Keyfob
Power Cord	10 ft
Power Connector	Wire
Recommended Circuit Size	30A
Recommended Circuit Size	HACR
Sound Emission	84-85 dBA @ 10 ft
<b>IMPELLER</b>	
Size	15"
Material	Single-piece, backward inclined, non-sparking/non-ferrous
<b>CARTRIDGE FILTER</b>	
Filter Media Type	Izumi Axtar Spunbond Media
Filter Efficiency	99.9% @ 0.2-2.0 microns
Filter Surface Area	220 Sq. Ft.
<b>SYSTEM DIMENSIONS AND CONSTRUCTION</b>	
Barrel/Cyclone Body	Heavy-gauge cold-rolled steel
Inlet	7" Diameter
Overall Height (with 55 Gallon Drum)	106"

# System Dimensions

Nominal dimensions shown with a 55 gallon drum. Dimensions subject to slight variations in manufacturing.

Top View

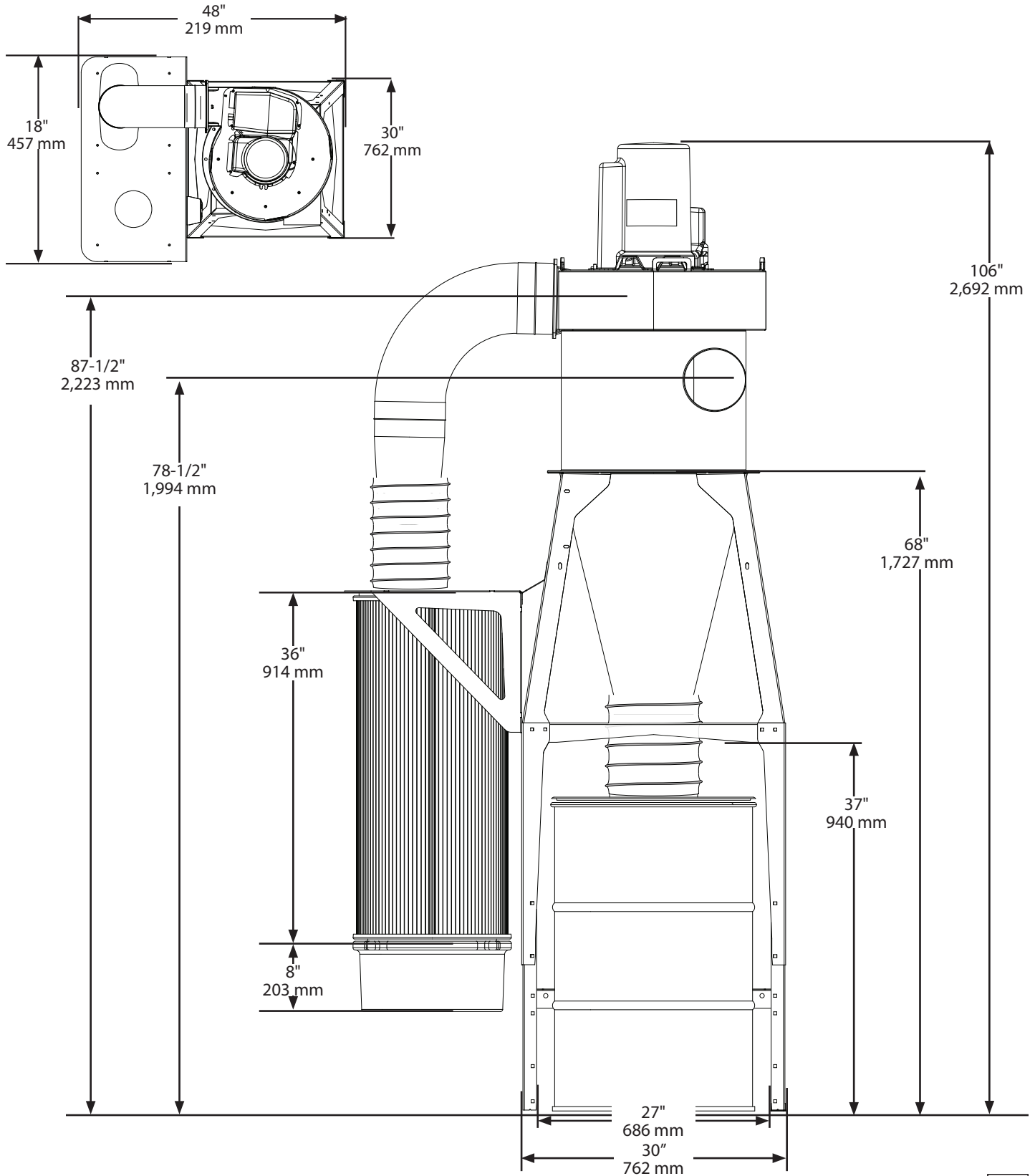

# System Contents



If you cannot find an item on the list examine the packaging materials very carefully. Certain components may have been pre-installed for shipping purposes. There may be hardware leftover.

ID	Part number	Part description	Qty	ID	Part number	Part description	Qty
A	BXI050318C	Motor Assembly 5 HP 3 PH	1	07C	AFT155175	5/16 Whiz Lock Nut	3
B	BHX020005B	Fan Housing	1	P	FCS183900	18" x 39" Filter	2
C	SXI002108	Barrel	1	Q	AHX001800	Hardware Kit	1
D	SCX002109	Cone	1	Q1	RGZ025050	Poron Gasket Roll	29'
E	ACB120000	8-12" Hose Clamp	2	Q2	QCZ080000	8" Duct Clamp	2
F	DHF090001	9" x 1' Diameter Flex Hose	1	Q3	AFB155155	5/16"-18 x 1" Flange Bolt	15
G	SEX550900	Steel Drum Lid w/ 9" Collar	1	Q4	AFW180000	5/16" Flat Washer	39
H	SES550000	55 Gallon Steel Drum w/ Clamp	1	Q5*	AFS015700	3/8-16" x 1-1/4" Hex Head Bolt	3
I	DEF080099	8" Outlet Adapter	1	Q6*	AFW190000	3/8" Flat Washer	20
J	DES900899	8" Plenum Elbow	1	Q7*	AFT000004	3/8" Whiz-Lock Nut	10
K	DWP877099	8x7x7 Pants Wye	1	Q8	AFB155190	5/16-18" x 1" Hex Head Bolt	12
L	ACB080000	6-8" Hose Clamp	4	Q9	AFT155175	5/16-18" Whiz-Lock Nut	12
M	DHF070000	7" Diameter Flex Hose	3'	Q10*	AFS015100	3/8-16" x 1" Hex Head Bolt	7
N	FPX020019	Dual Filter Plenum Plate	1	Q11	FGA000002	14" Grounding Cable with Two 8-18 x 3/8" Self-tapping Screws	1
O	AHX0021819	Filter Accessory Pack	1	R	STZ212300	Stand	1
01	BSC180000	Drop-in Silencer	2	S	STZ212301	Stand Extensions	1
02	AFT000001	5/16"-18 Thumb Nut	16	T	AXB999110B	Dust Sentry	1
03	AFW180000	5/16" Flat Washer	8				
04	AFJ051602	5/16"-18 x 2" J Bolt	16				
05*	AHX186200A	Filter Stacking Hardware Kit	2				
06	FPZ000018	Fine Dust Bin	2				
07	FPB210001	Dual Filter Adapter Bracket	2				
07A	AFB155175	5/16-18" x 3/4" Hex Head Bolt	3				
07B	AFW180000	5/16" Flat Washer	3				

Please unpack the parts carefully and confirm you have received each item listed here.

\*Additional parts are included in your hardware package.

## You will need the following tools:

GENERAL	FAN HOUSING	FILTER
8' Ladder	Razor Knife	Flathead Screwdriver
Level	Diagonal Cutters	7/16" Wrench
Scissors	Tape Measure / Ruler	7/16" Socket Wrench
1/2" Wrench	1/4" Socket	
1/2" Socket Wrench	Impact Driver	



# System Contents (Continued)

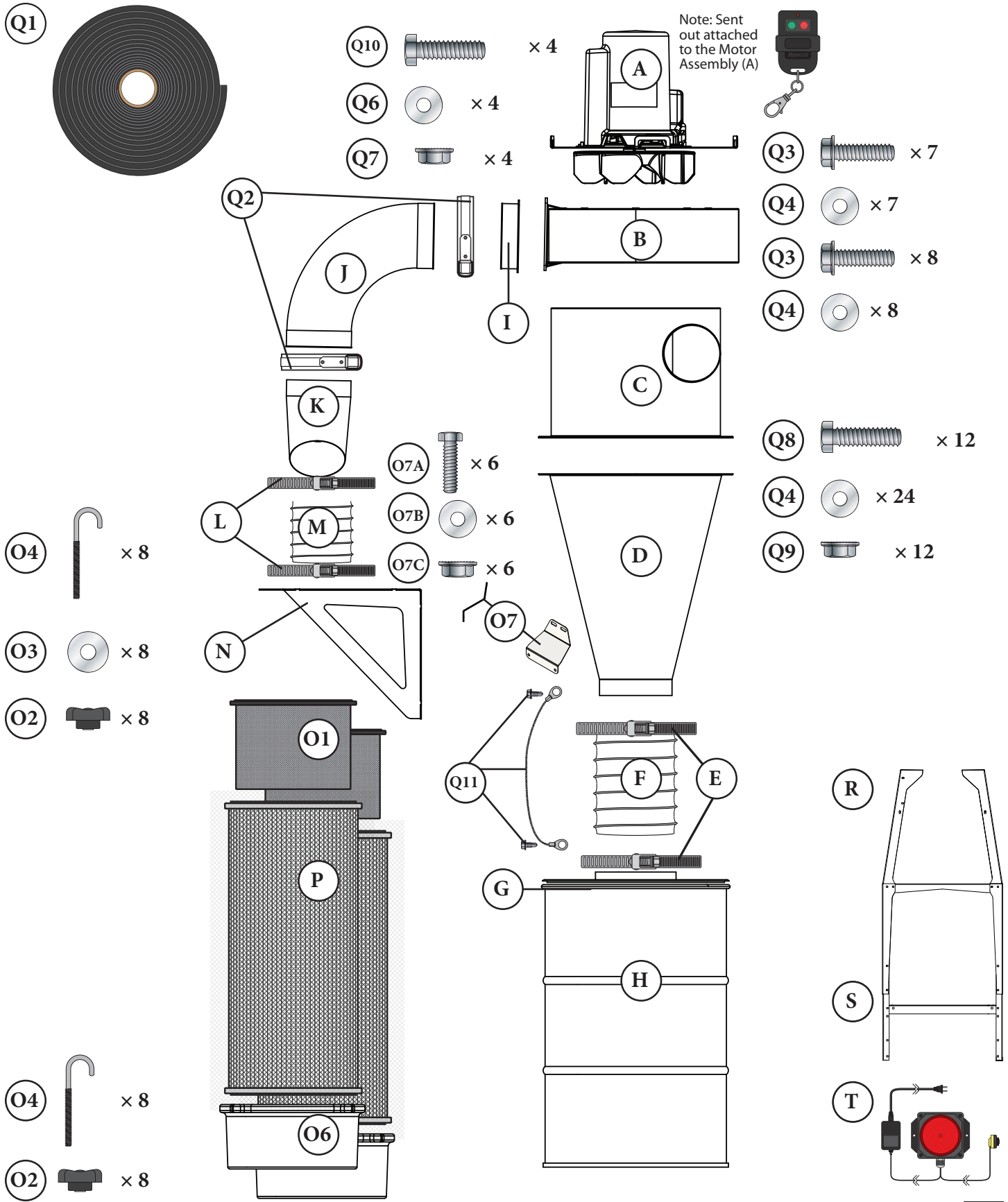

# Assembly Instructions



Before you start, determine which direction you want your filter to hang and which direction you want your duct work to enter the collector. The fan housing and cyclone barrel bolt holes are drilled at 45 degree increments; Some orientations are not possible.

*Tip: The collector will seem quieter if the outlet is aimed away from the area where people tend to work.*

✓ **CORRECT**

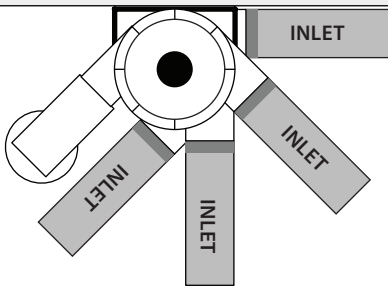

✓ **CORRECT**

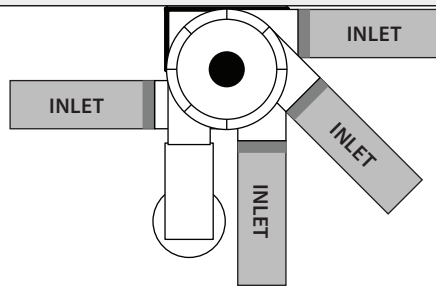

✗ **INCORRECT**

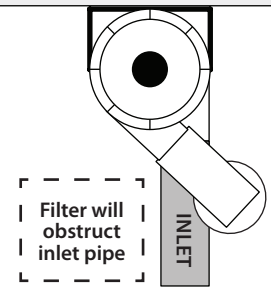

1

Assemble the Stand (R) and Stand Extensions (S) [FIG 1]. Refer to the instruction sheets included:

- Stand Instruction Sheet  
# ZBI000014
- Leg Extension Instruction Sheet  
# ZBI000013

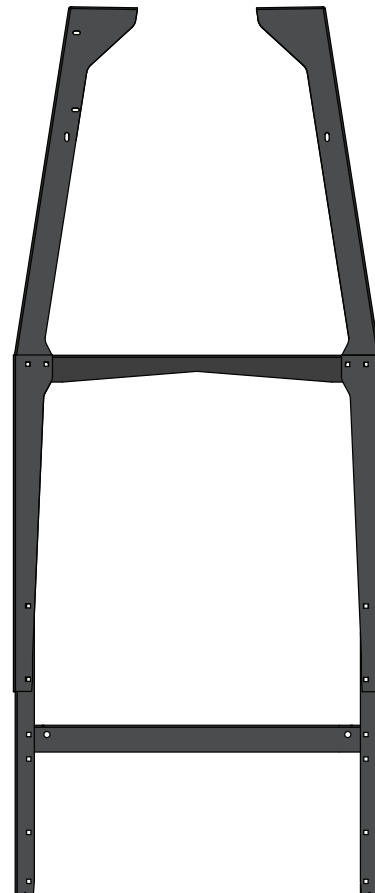

FIG. 1

# Assembly Instructions (Continued)

2

Apply Gasket (Q1) making sure that there is no gap where the ends meet:

- Apply to the top flange of the Cone (D) inside the bolt holes [FIG. 2a].
- Apply to the top rim of the Barrel (C) outside of the bolt holes [FIG. 2b].
- Apply to the Fan Housing's (B) outlet inside the bolt holes [FIG. 2c].
- Apply to the top of the Fan Housing (B) outside the bolt holes [FIG. 2d].

*Note: Dust collection systems cannot operate effectively if there isn't a complete seal. There must be NO air leaks.*

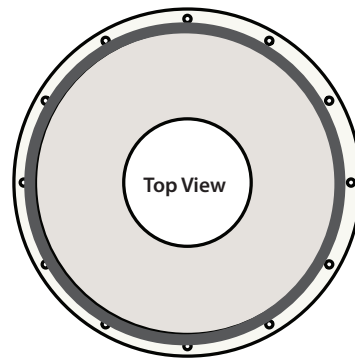

FIG. 2a

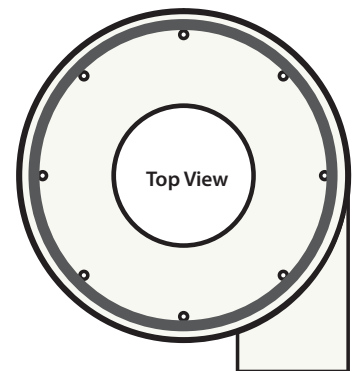

FIG. 2b

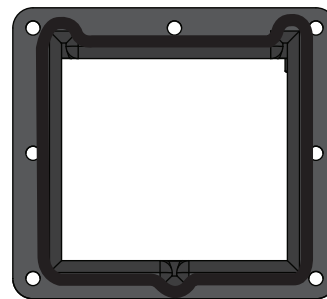

FIG. 2c

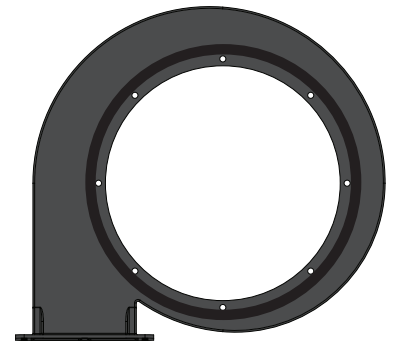

FIG. 2d

3

Lift the Cone (D) onto the Stand (R), making sure to align the Cone's flange holes with those on the Stand [FIG 3].

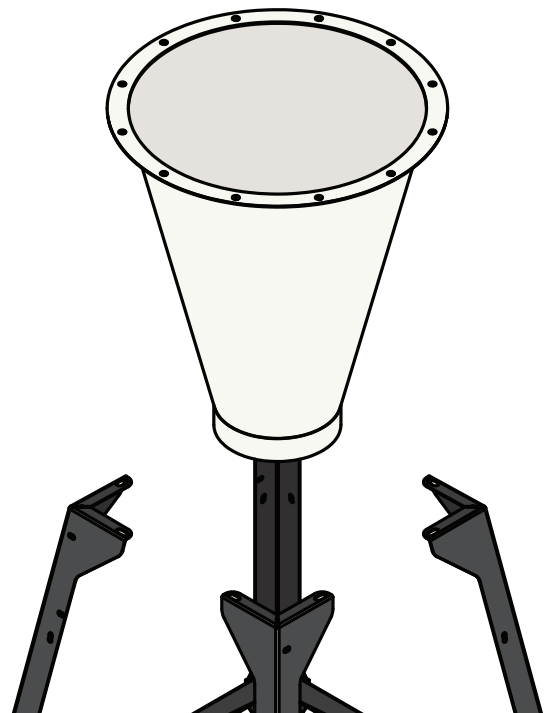

FIG. 3

# Assembly Instructions (Continued)

4

Once your Cone (D) is aligned with the Stand (R), lift the Barrel (C) onto the Cone, making sure to align the corresponding flange holes. Secure both components to the stand using twelve Hex Head Bolts (Q8), twenty-four Flat Washers (Q4), and twelve Whiz-Lock Nuts (Q9) [FIG 4].

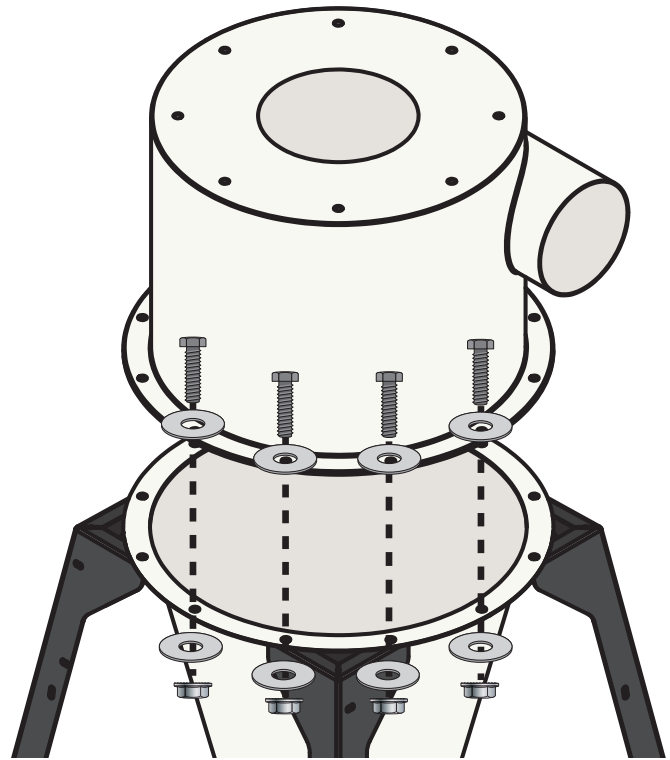

FIG. 4

5

Lift the Fan Housing (B) onto the Barrel (C), making sure it is oriented so that the molded “UP” text is visible. Align the housing’s holes with the holes in the barrel and keep in mind the direction you want your outlet to face. [FIG. 5]

Secure the Fan Housing onto the Barrel using eight Flange Bolts (Q3) and eight Flat Washers (Q4).

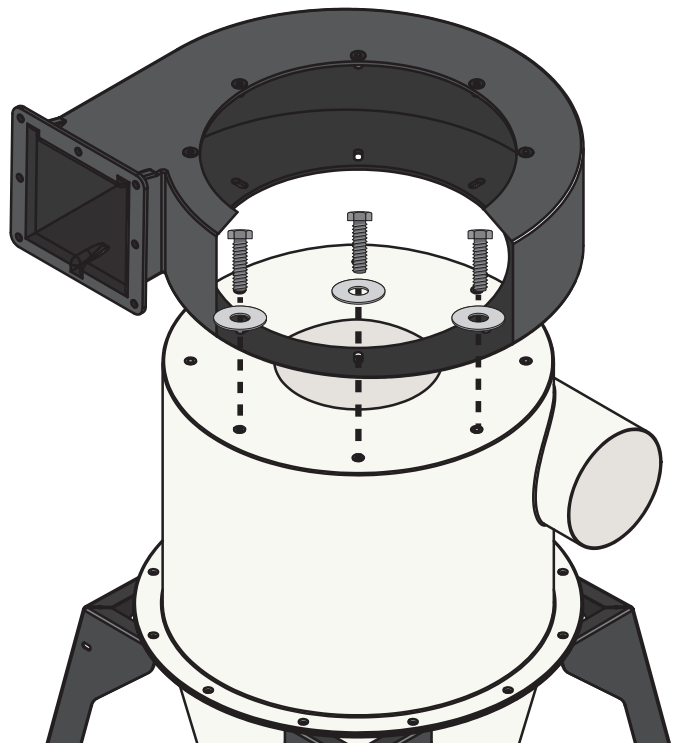

FIG. 5

# Assembly Instructions (Continued)



**THE MOTOR ASSEMBLY IS VERY HEAVY AND CUMBERSOME; BE SURE TO HAVE ADEQUATE HELP WHEN LIFTING!**

**6**

Carefully lift Motor Assembly (A) to top of Fan Housing (B) and align the Fan Housing holes with the motor plate holes following the orientation shown in [FIG. 6a].

Secure the Motor Assembly to the Fan Housing using seven Flange Bolts (Q3) and seven Flat Washers (Q4). [FIG. 6b]

*Note: The eighth hole on the Fan Housing (B) does not require a bolt because it is inaccessible [FIG. 6a].*

Unwrap the braided filter grounding wire from the Motor cowling and let hang loose for future grounding steps [FIG. 6c]. Also, unclip the Remote from the Filter Grounding Wire [FIG. 6d].

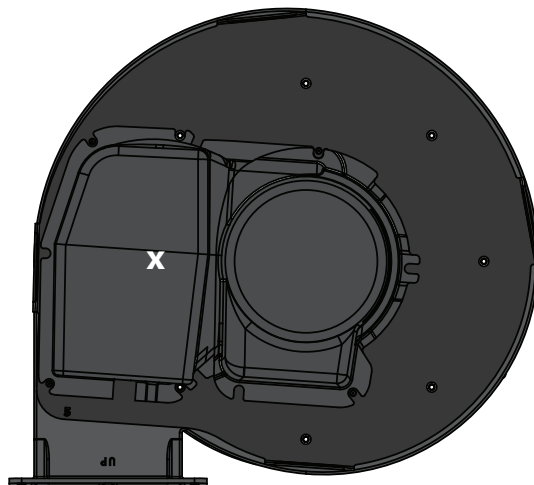

FIG. 6a

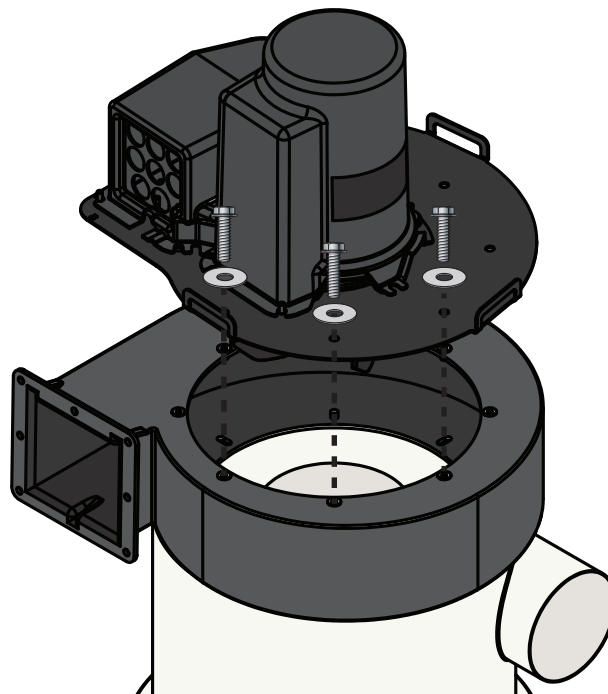

FIG. 6b



FIG. 6c



FIG. 6d

# Assembly Instructions (Continued)

7

Attach the 8" Outlet Adapter (I) onto the outlet of the Fan Housing (B) with four Hex Head Bolts (Q10), eight Flat Washers (Q6), and four Whiz-Lock Nuts (Q7) as shown in [FIG. 7].

*Note: Tighten firmly but do not over compress the gasket.*

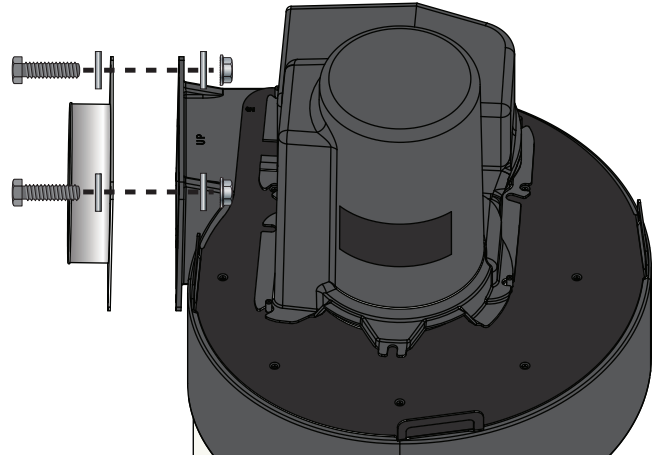

FIG. 7

8

Open an 8" Duct Clamp (Q2) and slip it over the 8" Plenum Elbow (J) [FIG. 8a]. Mate the Elbow to the 8" Outlet Adapter (I) and close the Clamp over the rolled ends. [FIG. 8b] Lock the Clamp in place using the provided cotter pin [FIG. 8c].

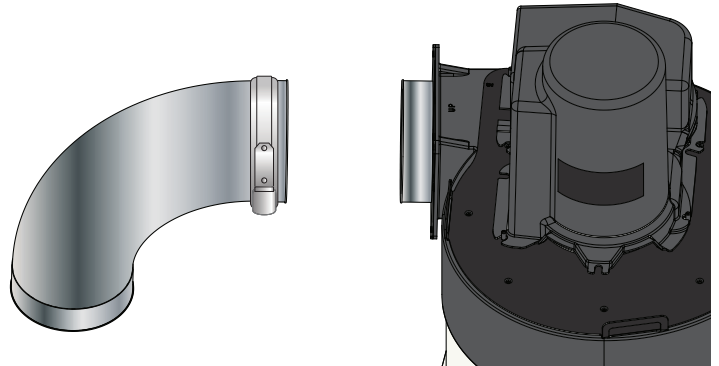

FIG. 8a

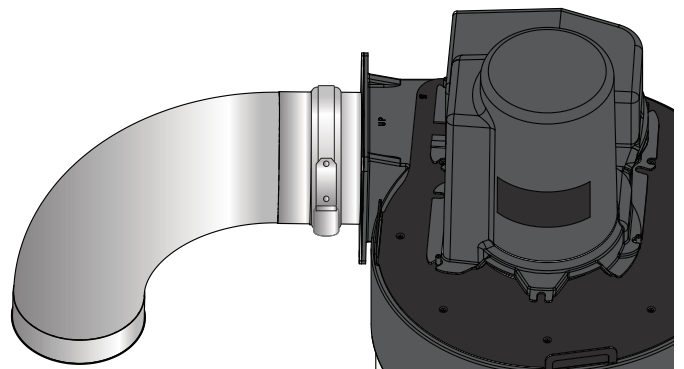

FIG. 8b



FIG. 8c

# Assembly Instructions (Continued)

9

Attach each Dual Filter Adapter Bracket (O7) to the Dual Filter Plenum Plate (N) with two Hex Head Bolts (O7A), two Flat Washers (O7B) and two Whiz-Lock Nuts (O7C) as shown in [FIG. 9A] and [FIG. 9B].

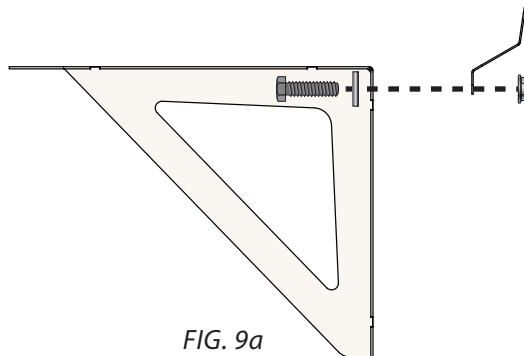

FIG. 9a

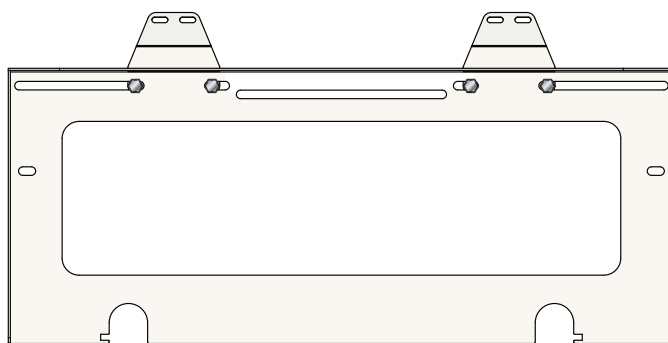

FIG. 9b

10

Attach the Filter Plate Assembly (N, O7) to the Stand (R) with two Hex Head Bolts (O7A), two Flat Washers (O7B) and two Whiz-Lock Nuts (O7C) as shown in [FIG. 10A] and [FIG. 10B]. Secure the Dual Filter Plate Assembly in place using the Stand's previously installed hardware from Step 1.

*Note: Hardware should be finger tightened first for ease of assembly when securing Filter Plate Assembly.*

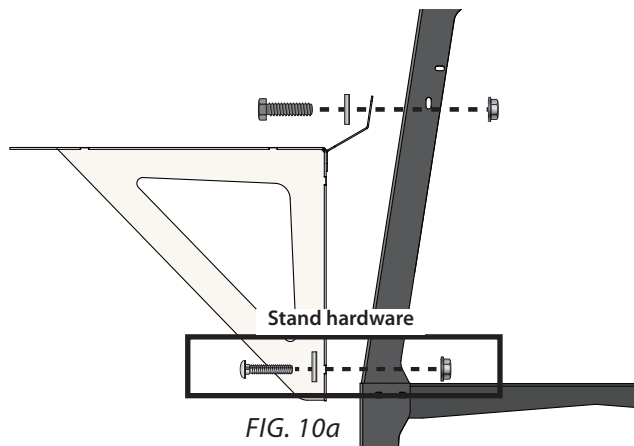

FIG. 10a

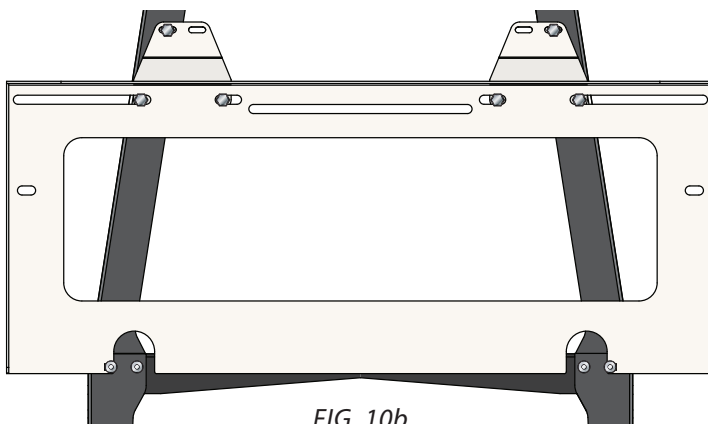

FIG. 10b

# Assembly Instructions (Continued)

11

Open an 8" Duct Clamp (Q2) and slip it over the 8" Plenum Elbow (J). Mate the Elbow to the 8x7x7 Pants Wye (K) and close the Clamp over the rolled ends [FIG. 11a]. Lock the Clamp in place using the provided cotter pin [FIG. 11b].

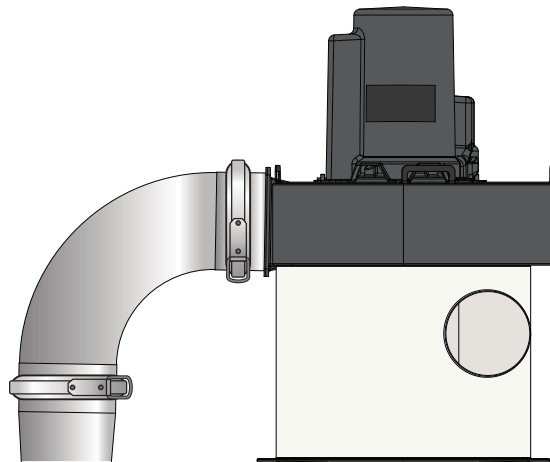

FIG. 11a



FIG. 11b

12

Cut the 7" Diameter Flex Hose (M) in half using a razor knife and diagonal cutter to cut through the clear lining and reinforcing wire. [FIG. 12a].

Attach the 7" Diameter Flex Hose to the 8x7x7 Pants Wye (K), and secure it in place with the 6-8" Hose Clamp (L). Repeat the process to attach the opposite end of the Hose onto each opening on the Dual Filter Plate (N) [FIG. 12b].

*Note: The hose is a snug fit. Pull ends up little by little to work the hose onto the cyclone's discharge. Pliers can be used to grab the reinforcing wire and aid in pulling the hose over the opening.*

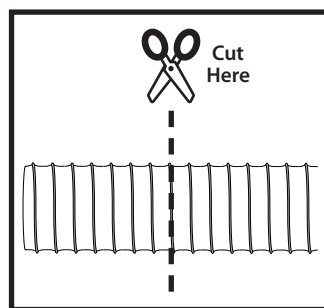

FIG. 12a

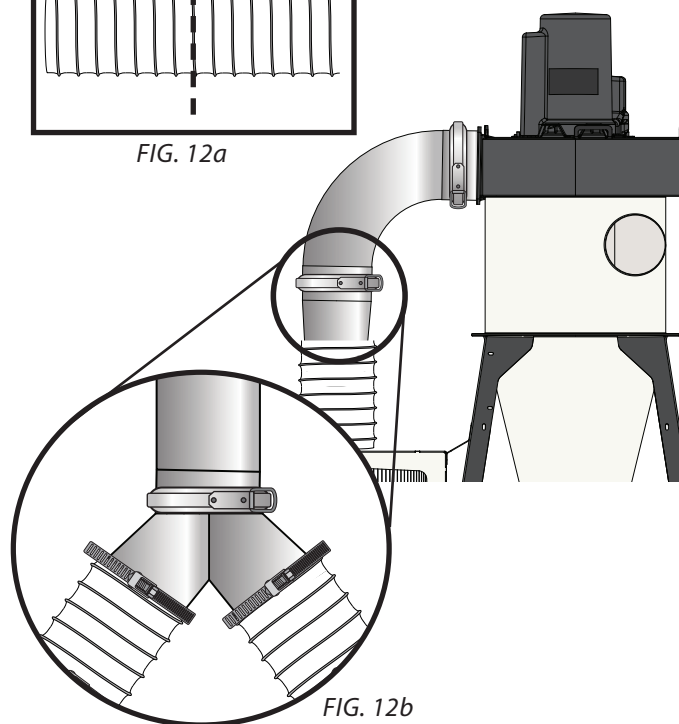

FIG. 12b



# Assembly Instructions (Continued)

13

Insert the Drop-In Silencer (O1) into the top of the Filter (P) [FIG. 13].



FIG. 13

14

Attach each Filter (P) to the Dual Filter Plate (N) with four J-Bolts (O4), four Flat Washers (O3) and four Thumb Nuts (O2) as shown in [FIG. 14].

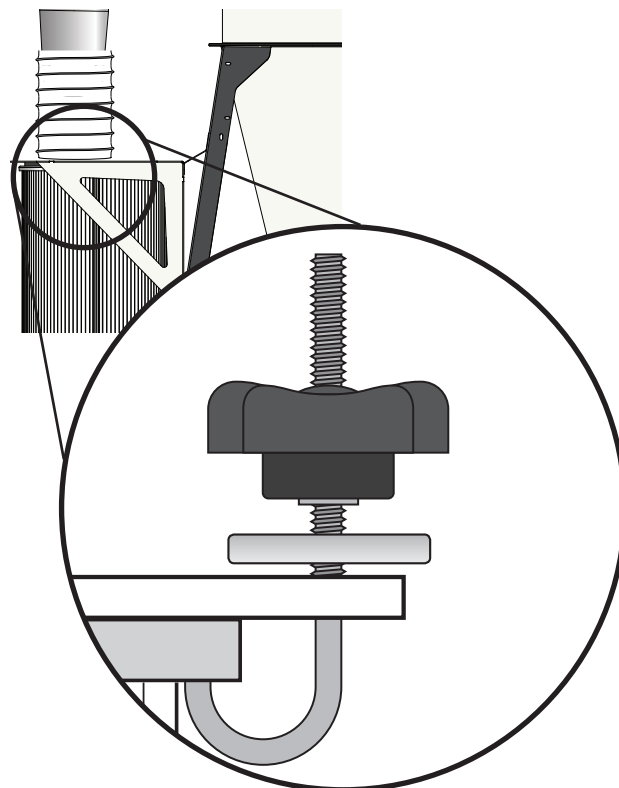

FIG. 14

# Assembly Instructions (Continued)

15

Attach a Fine Dust Bin (O6) to each Filter (P) with four J-Bolts (O4) and four Thumb Nuts (O2) as in [FIG. 15].

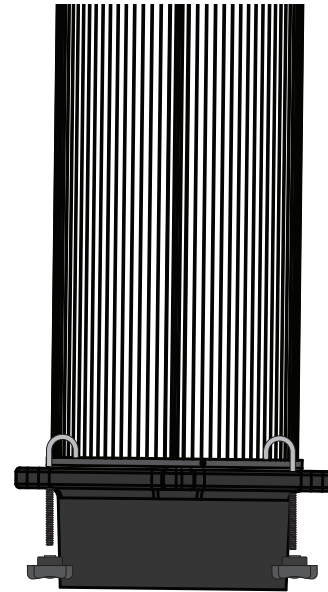

FIG. 15

16

To ground the filter, attach the ring terminal on the braided ground wire from the Motor Assembly (A) to a J-bolt (O4) on the Dual Filter Plate (N) under the Thumb Nut (O2), then attach the alligator clip to the filter's cage [FIG. 16].

*Note: If you need to extend the wire, you can use any 16 gauge copper stranded wire and connect with wire nuts.*

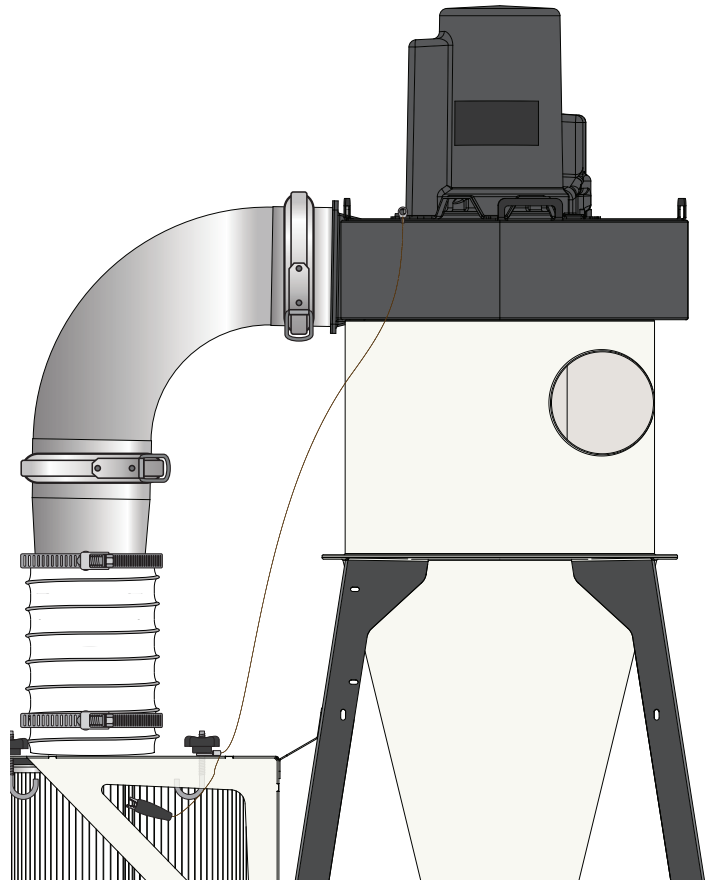

FIG. 16

# Assembly Instructions (Continued)



The flex hose connects the cyclone to the dust bin below and only requires enough height to allow the lid to be lifted from the bin. You may shorten the provided 1' hose length as needed.

17

Attach Hose (F) to the Cone's (D) discharge, and secure it in place with the Clamp Band (E). [FIG. 17]

*Note: The hose is a snug fit. Pull ends up little by little to work the hose onto the cyclone's discharge. Pliers can be used to grab the reinforcing wire and aid in pulling the hose over the opening.*

Position the Drum (H) and Lid (G) under the Cone and repeat the process to attach the opposite end of the Hose onto the lid's collared inlet.

Unclamp the Lid and test to see if the Drum is easy to remove from underneath the Cone.

If there is insufficient clearance for removing the Drum, you may trim the Hose using a razor knife and diagonal cutter to cut through the clear lining and reinforcing wire.

*Note: Be careful to only remove 0.5" at a time so as not to over trim.*

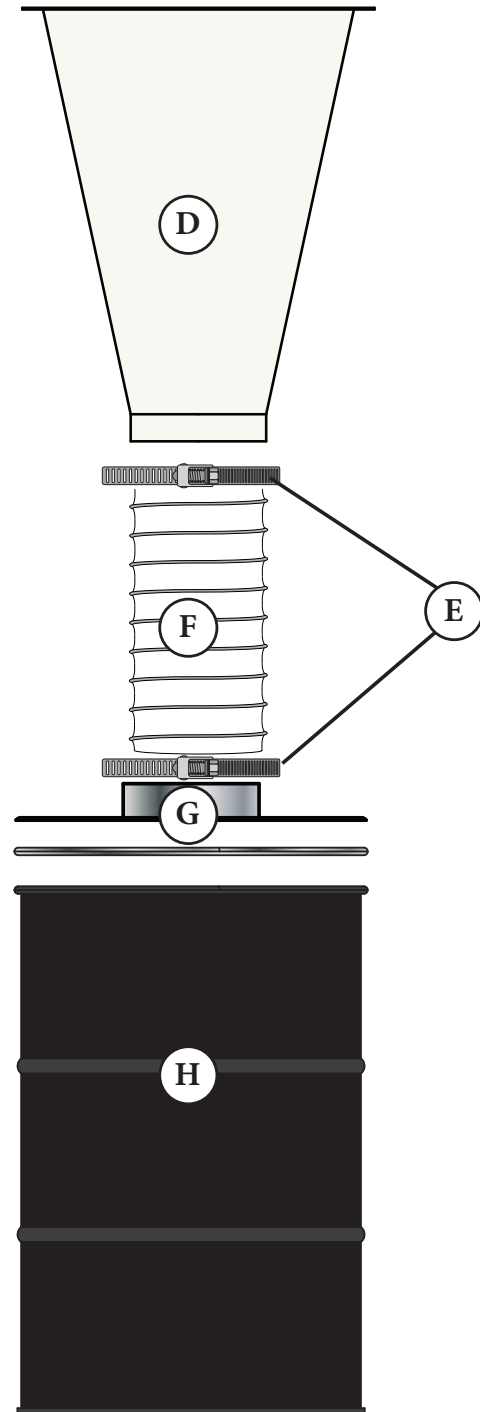

FIG. 17

# Assembly Instructions (Continued)

18

Statically ground the Drum (H) by attaching the 14" Grounding Cable (Q11); Drive the 3/8" Self-Tapping Screw through its eyelet and into the bottom of the Cone (D) just above the installed Flex Hose (F). Repeat using the second 3/8" Self-Tapping Screw on the Lid's Collared Inlet (G) [FIG. 18].

*Note: If you need to extend the wire, you can use any 16 gauge copper stranded wire and connect with wire nuts*

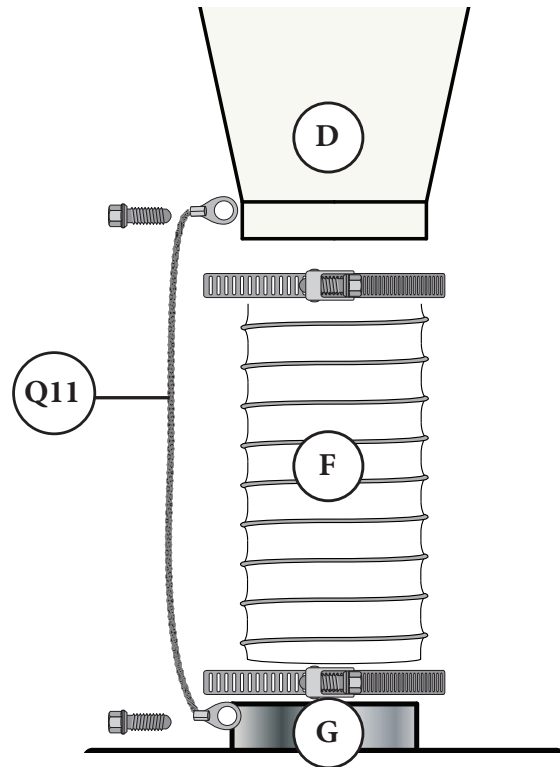

FIG. 18



**ENSURE THAT ALL ELECTRICAL POWER TO THE SYSTEM IS DISCONNECTED BEFORE PROCEEDING WITH FURTHER STEPS.**

19

Use the adhesive of your choice to temporarily secure the starter to the wall [FIG. 19].

To permanently secure the starter to the wall proceed to Step 20.

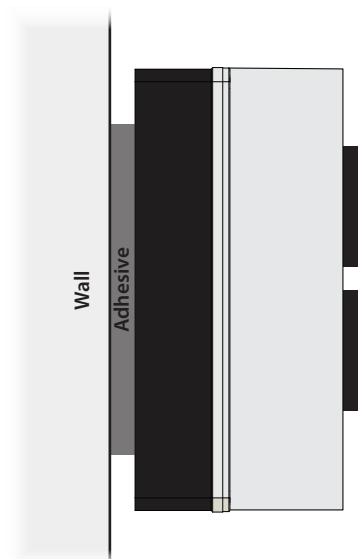

FIG. 19

# Assembly Instructions (Continued)

20

To permanently secure the starter to the wall, take off the starter cover by removing the top and bottom screws and exposing the overload and contact connections [FIG 20a]. Set aside the screws.

- Place a mark through the four mounting holes [FIG 20b].
- Use appropriate fasteners for the wall type you are installing your system onto.
- Drill into the wall at the marked locations.
- Secure the starter to the wall.

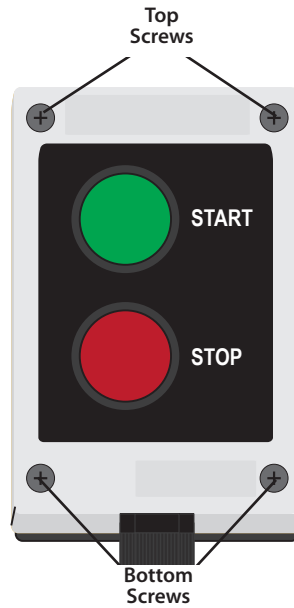

FIG. 20a

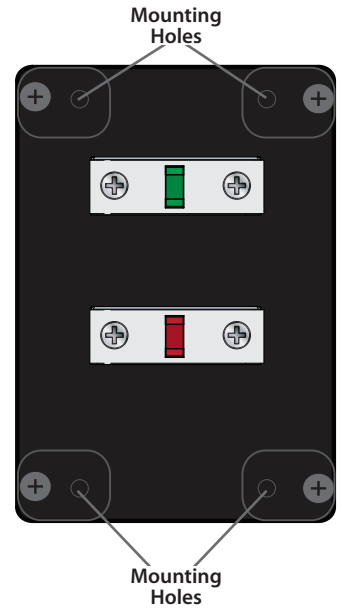

FIG. 20b

21

Reattach the cover with the screws set aside in Step 20 [FIG 21].

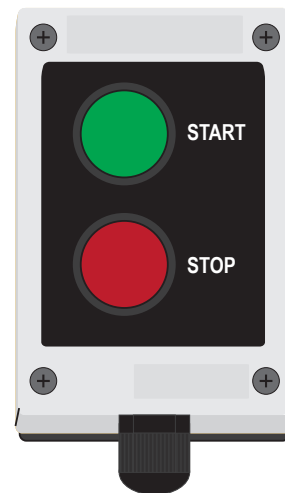

FIG. 21

22

Install the Dust Sentry (T) [FIG. 22] by referencing the included instruction sheet:

- Dust Sentry Sheet #ZBI000002A

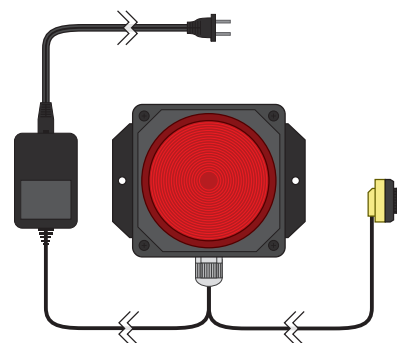

FIG. 22

# Maintenance



**UNPLUG YOUR UNIT BEFORE  
SERVICING OR CLEANING**

## Cleaning the Filter

Proper filter cleaning should not be neglected as a dirty filter can significantly affect your dust collector's performance and the overall lifespan of your filter. The following steps should be done while the filter is still attached to your system:

1. WEAR A DUST MASK AND EYE PROTECTION WHILE CLEANING THE FILTER.
2. Turn off the dust collector and wait for the system's fan blower to come to a complete stop.
3. Use a hand-held, compressed air nozzle with a pressure between 30 to 60 PSI to blast air along the filter's exterior pleating. Hold the air nozzle at a 20 degree angle and at least 6" away from the filter; Closer blasts may damage the filter material. Direct air out and away from anyone in the area.
4. Wait a few minutes for the dust to settle, then remove the fine dust bin at the bottom of the filter.
5. Dispose of dust carefully and then reconnect the dust bin.

## Emptying the Drum

When first using the dust collector, check the drum regularly to get an idea of how often it needs to be emptied. If the drum becomes overfilled, the dust will be sucked into the intake barrel and into the filter.

How quickly the drum will fill up is based on the type of work being done at the time. For example: fine dust from a sander or table saw will slowly fill the drum while curly shavings from a planer or jointer will quickly fill the drum.

## Lubricating the Motor

Per Baldor's specifications, their 2-pole motors (3,600 RPM) are to be lubricated every 5,500 hours. Refer to the Table below to determine if your motor's Lubrication Interval must be adjusted. For example, a system operating in a moderately corrosive area with an ambient temperature of 109° F (43° C) would qualify as the "Severe" service condition, and should instead be lubricated every 2,750 hours.

**A right angled grease coupler will be needed for this operation.**

1. Motors can be greased while stopped, at less than 176° F (80° C), or while running.
2. Clean the motor's grease fitting, or if equipped with slotted grease screws, clean the area around the grease hole. If the motor has a purge plug, remove it.
3. Apply grease gun to fitting (or grease hole). Add 0.3 ounces (8.4 grams) of Mobil Polyrex grease by weight, or 0.6 cu. in. (2 teaspoons) of Mobil Polyrex grease by volume.
4. Slowly apply the recommended amount of grease, taking one minute or so to apply. Too much grease or injecting grease too quickly can cause premature bearing failure.
5. Operate the motor for 20 minutes; Reinstall purge plug if previously removed.

*Caution: Keep grease clean. Mixing dissimilar grease is not recommended.*

LUBRICATION INTERVAL TABLE			
Severity of Service	Maximum Ambient Temperature	Atmospheric Contamination	Lubrication Interval Multiplier
Standard	104° F (40° C)	Clean; Little Corrosion	1.0
Severe	122° F (50° C)	Moderate Dirt; Corrosion	0.5
Extreme	> 122° F (50° C) or Class H Insulation*	Severe Dirt; Abrasive Dust; Corrosion	0.1
Low Temperature	< -22° F (-30° C)**		1.0

\* Special HIGH temperature grease is recommended

\*\* Special LOW temperature grease is recommended

# Troubleshooting

PROBLEM	CAUSE	SOLUTION
Motor Overheating/System Tripping (The motor's overload will trip if the motor is overheating)	Air leaks between the dust collector and dust bin	<ol style="list-style-type: none"> <li>1. The lid of the dust drum must be in place, have a foam seal, and be well seated when operating the dust collector.</li> <li>2. Make sure flex hose is not torn and the hose clamps are tight.</li> <li>3. Check for holes or leaks in the dust barrel.</li> </ol>
	Motor not properly wired	<ol style="list-style-type: none"> <li>1. Check wire connections.</li> <li>2. Check fan impeller rotation.</li> <li>3. Check breaker box to make sure power supply is correct for motor.</li> </ol>
Poor Dust Pick-Up at Tools System Lost Suction	Ductwork issues	<ol style="list-style-type: none"> <li>1. Check length of duct runs, duct diameters, and hood design compared to ductwork design guidance.</li> <li>2. Make sure all ductwork is sealed. Large air losses will occur even through small cracks in the ductwork. Use silicone, duct tape or duct mastic compound as a sealant.</li> <li>3. Check for air leaks between collector and dust drum.</li> <li>4. Close all unused blast gates at your woodworking machines.</li> <li>5. Check for a restricted pipe, too small a hood port, or too small a branch line.</li> <li>6. Be sure that your filter is clean.</li> </ol>
Filter Clogging	Large chips clogging the filter	<ol style="list-style-type: none"> <li>1. Check for a leak in the dust drum, flex coupling, or lid. Check for split or torn flex coupling.</li> <li>2. Make sure dust drum has not over filled. Dust drum should be emptied before the dust reaches top of container.</li> <li>3. Interruption of air flow, such as vacuuming chips with a flex hose connection, will increase filter maintenance.</li> </ol>
	Fine dust clogging the filter	<ol style="list-style-type: none"> <li>1. Air flow to the collector may be restricted. The collector needs the equivalent of at least a 4" diameter cross-section open to allow adequate air volume and speed for pre-separation in the cyclone stage of the collector. If you are using a woodworking machine with only one 2" diameter dust port, partially open another blast gate to compensate.</li> <li>2. Check for excessive elbows at cyclone inlet as explained in the mounting collector section.</li> <li>3. Heavy sanding with a drum sander or fine grit paper will cause the pleated filter media to blind sooner than with larger size dust. Clean filter more often with compressed air.</li> </ol>
System Will Not Turn On	VFD may need to be reset	<ol style="list-style-type: none"> <li>1. Remove the cowling and press the reset button.</li> <li>2. If there is no room to remove the cowling, unplug your system for 1 minute.</li> </ol>



If you continue to experience difficulty with your dust collector, call Oneida Air Systems' Customer Service Department at 1-866-387-8822 or email [support@oneida-air.com](mailto:support@oneida-air.com).

# F.A.Q.

---

## **What dust can be collected?**

Oneida Air Systems' dust collectors are designed and tested for wood and wood dust. They can and have been used effectively for various other dusts and chips, such as drywall dust, paper dust, agricultural dust, metal chips and other forms of debris. The customer is, however, cautioned that some common materials when cut, ground or processed by machinery may become very dangerous: highly toxic, flammable, or deflagrable and explosive. The user must ensure that the dust collection system is used in accordance with national, state, local, NFPA, OSHA and all other applicable codes.

## **Can this be used for wet applications as well?**

No. This system is designed for use collecting dry materials only.

## **What is a static dissipative material?**

This term refers to the range of conductivity that a material has. Static dissipative materials range from 10<sup>6</sup>-10<sup>12</sup> Ohms.

## **How often should I clean the dust collector's cartridge filter?**

This can vary widely depending on how often your dust collector is used and what kind of dusts it's exposed to, but you should typically clean it only once you've noticed a considerable drop in suction performance. In our experience, this can be around once per year, but with heavy amounts of sanding it could be as often as once per month.

## **When should I replace this filter?**

With regular maintenance, our cartridge filters can easily last up to 5 years. Your filter should only be replaced if thorough cleanings do not help to restore your suction performance.

## **How do I clean this filter?**

Clean this filter using compressed air blown from the outside of the filter. For further instructions see the Maintenance Section.

## **How do I troubleshoot an air leak with my cyclone?**

Even a small leak can significantly affect the overall separation performance of the cyclone. If you can't audibly pinpoint where the leak might be coming from, one of the simplest ways to check for air leaks is with a smoke test. For further instructions see the Maintenance Section.

## **Should the inlet reducer for my dust collector be crimped or straight?**

The inlets on all of our dust collectors are sized to fit standard ductwork. If you need a reducer to connect to ductwork that's smaller than your collector's inlet, the end of the reducer that connects to the inlet will need to be crimped, so that it will fit inside the inlet..

## **Is this product compatible with Quick-Clamp Duct?**

Yes, but you will first need to install a Machine Adapter into the dust collector's inlet. These adapters are smaller on the raw end than traditional ducting so that they can slip into the ports on systems and tools (i.e. a 5" Quick-Clamp Duct Machine Adapter will measure ~4.9" O.D. on the raw end).



# F.A.Q. (Continued)

---

## **Where do I mount the included Dust Sentry?**

The strobe can be mounted anywhere convenient that is within reach of the wiring.

## **Can I lengthen the Bin Level Sensor power cord?**

The 8' power cord can be extended to any length using wire of the same gauge or higher.

## **Why does the Bin Level Indicator flash when the bin is empty?**

Because the Dust Sentry works via an adjustable infrared sensor, it can sometimes show false positives with an empty container because of the reflective surface at the bottom of the steel drum.

This issue will go away soon after the system is used. Once the bottom of the drum has sawdust on it, the Dust Sentry should no longer give a false positive. It can also be resolved by painting/coloring the inside bottom of the drum so that it is no longer reflective enough to affect the sensor..

## **How do I adjust the Bin Level Sensor?**

Adjust the detection of the dust level of the infrared sensor by rotating the Level Set Screw. Turning it towards the plus sign (+) will lengthen the range of the sensor; turning it towards the minus sign (-) will shorten the sensor's range. DO NOT force the level set screw.

## **Can the Dust Sentry Panel be mounted outside?**

No, the Dust Sentry is for indoor use only.

## **Should I remove the internal drop-in foam silencer from my filter before installing the Stacking Sound Filter?**

No, you do not need to remove the internal foam filter. This Drop-in Silencer can be used in conjunction with the Stacking Sound Filter.

## **Can Stacking Sound Filters be combined?**

Yes; If you have room underneath the filter assembly (varies by model) then you can stack multiple sound filters, however, the resulting noise reduction per filter is not linear (additive) and is subject to diminishing returns. For example:

1 Sound Filter = 6-7 dBA total reduction

2 Sound Filters = ~9 dBA total reduction

3 Sound Filters = ~10 dBA total reduction

4+ Sound Filters = ~10 dBA total reduction

## **Is this remote IR or RF?**

All of our current remote control products operate via Radio Frequency (RF).

## **What type of battery does the keyfob remote (item #AMR...) use?**

The remote control keyfob uses an A23 type battery.

# Recommended Accessories

---



## 18" x 39" Spunbond Filter

#FCS183900

- Specially designed for high airflow performance with minimal pressure drop.
- Durable polyester pleating material with external, reinforcing steel wire frame.
- Independently lab tested and verified filtration media.



## 18" x 36" HEPA Media Filter

#FCS183600HF

- Independently tested G.E. Certified H12 HEPA filter media.
- Wide-spaced pleated filters with teflon-like coating for quick and easy dust removal.
- Equipped with patented FlameGuard™ arrestor mesh for added safety.



## 55 Gallon Liner Bag Holder

#ABX000055

- Holds the liner bag open within your dust collector's waste container.
- Several finger holes for easy lifting and removal from the liner bag.
- 32" Tall for 55 Gallon.



## 35-55 Gallon Heavy-Duty Plastic Liner Bag

#VAB251555

- Lines the inside of large, 35 to 55 gallon containers for fast and simple waste disposal.
- Heavy thickness protects against tearing from wood chips or other sharp debris.
- 22" x 22" x 55"



## RF Remote Control Key Fob

#AMR000000

- Sends long range wireless signal via radio frequency.
- Works at long distances and even through walls!
- Compatible only with systems that include a magnetic motor starter control box.

# Recommended Accessories (Continued)



## Universal Drum Dolly

#SDD990000

- Fits nearly any cylindrical waste bin sold by Oneida Air Systems.
- Includes five 2" non-marking castor wheels (3 non-locking, 2 locking).
- Requires Leg Extension Kit (Item #STZ212301) if used with a stand mounted system.



## Flex Hose 9" Diameter by 5' Long

#DHF090500 (also available in 1' and 10' lengths)

- Highly flexible hose made from abrasion resistant anti-static polyurethane.
- Reinforced with steel wire-helix for heavy-duty usage.
- Transparent hose makes it easy to spot and clear potential blockages.

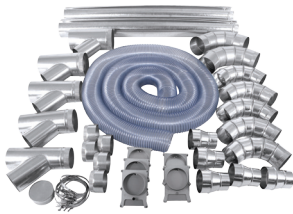

## 6" Deluxe Ductwork Starter Kit

#KDZ000005

- Contains all the essentials for building a ductwork system to connect five tools to your collector's inlet, with blast gates provided for each drop.
- Includes hose connect fittings and reducers for your tool ports.
- Recommended for personal shops looking to jump start their dust collection.



## 7" Deluxe Ductwork Starter Kit

#KDZ000007

- Contains all the essentials for building a ductwork system to connect five tools to your collector's inlet, with blast gates provided for each drop.
- Includes hose connect fittings and reducers for your tool ports.
- Recommended for personal shops looking to jump start their dust collection.



## Floor Sweep Terminal Ductwork Kit

#KDZ000011

- Contains all the essentials for installing a floor sweep terminal into your dust collection ductwork system.
- This kit features a pre-crimped adjustable elbow for simple installation into existing 5" diameter duct, and a cast aluminum blast gate for managing airflow to the terminal.

# Warranty Information

---

## Limited Warranty – Activate online at [oneida-air.com/warranty](http://oneida-air.com/warranty)

Oneida Air Systems®, Inc. (OAS) warrants the 5HP High Vacuum Cyclone Dust Collector w/ SMART Boost for a period of 2 years, to the original purchaser from the date of purchase, unless otherwise specified. Items not manufactured by Oneida Air Systems are limited to their own manufacturer's warranties. All electrical items such as magnetic starters, remotes, sensors, pumps, bin sensors, bag grippers, etc. and accessories are limited to 90 days. Oneida Air Systems warrants that the product will be free from defects in materials and workmanship.

This is Oneida Air Systems' sole written warranty and any and all warranties that may be implied by law, including any merchantability or fitness, for any particular purpose, are hereby limited to the duration of this written warranty. Oneida Air Systems does not warrant or represent that the merchandise complies with the provisions of any law or acts unless the manufacturer so warrants. This warranty does not apply to defects due directly or indirectly to misuse, negligence, accidents, abuse, repairs, alterations, improper wiring or lack of maintenance. In no event shall Oneida Air Systems' liability under this warranty exceed the purchase price paid for the product and any legal actions brought against Oneida Air Systems shall be tried in the State of New York, County of Onondaga.

The buyer is cautioned to install and operate Dust Collectors in accordance with prescribed Federal, State, OSHA, NFPA, local codes and regulations. This equipment should be installed/wired by a licensed electrician following all applicable codes. Local codes can be significantly different from national codes. The customer assumes the responsibility for contacting their insurance underwriter with regard to specific application requirements of venting or if additional fire protection and safety equipment may be required. Oneida Air Systems shall in no event be liable for death, injuries to persons or property or for incidental, and contingent, special, or consequential damages arising from the use of our product.

Oneida Air Systems makes every effort to accurately represent our products and prices, however Oneida Air Systems reserves the right to make changes to products and prices at any time. As a manufacturer, Oneida Air Systems reserves the right to change product specifications at any time in an effort to achieve better quality products.



**ONEIDA AIR SYSTEMS SHALL IN NO EVENT BE LIABLE FOR DEATH, INJURIES TO PERSONS OR PROPERTY OR FOR INCIDENTAL, AND CONTINGENT, SPECIAL, OR CONSEQUENTIAL DAMAGES ARISING FROM THE USE OF OUR PRODUCT.**



## SAFETY WARNING - PLEASE READ

Before Purchasing or Installing a dust collection system the buyer is cautioned to do so in accordance with prescribed Federal, State, Local, OSHA, NFPA, and any other applicable codes or regulations relating to the type of dust(s) you are collecting.

**SOME TYPES OF DUST UNDER CERTAIN CONDITIONS HAVE THE POTENTIAL TO BE EXPLOSIVE.**

Oneida Air Systems is not responsible for how the dust collector is used or installed. Dusts with deflagration or explosion risks, such as wood dust, may require additional safety equipment including but not limited to; venting, spark detection, suppression systems, back draft dampers or may require installation in an outside location or in a protected area away from personnel. The customer assumes the responsibility for contacting their insurance underwriter with regard to specific engineering controls or application requirements. (We suggest you reference NFPA 664, 654 and 68 codes for more information) Oneida Air Dust Collection Systems may not be suitable for some applications and are not designed to be used in explosive atmospheres. Oneida Air Systems equipment should only be installed and wired by a licensed electrician following all applicable local and national electrical codes.

Some dust created by power sanding, sawing, grinding, drilling, and other construction activities contains chemicals known to cause cancer, birth defects or other reproductive harm. Some examples of these chemicals are: Lead from lead-based paints; Crystalline silica from bricks, cement and other masonry products; Arsenic and chromium from chemically-treated lumber; etc.

Your risk from these exposures varies, depending on how often you do this type of work. To reduce your exposure to these chemicals, work in a well ventilated area, and work with approved safety equipment, such as those dust masks that are specially designed to filter out microscopic particles. Oneida Air Systems recommends using additional approved safety equipment such as an approved OSHA and NIOSH dust mask or respirator.

Oneida Air Systems makes every effort to accurately represent our products, specifications and prices; however Oneida Air Systems reserves the right to make changes to products and prices at any time. As a manufacturer, Oneida Air Systems reserves the right to change product designs and specifications at any time.





*The* **Industry Leader in Dust Collection**

**Thank you for your business!**

Regardless of where you purchased your system, if you have any questions or issues with missing / damaged parts, please call Oneida Air Systems first to let us help resolve your problem. We fully stand behind the quality of our products and place the utmost value on customer satisfaction.

We want to do everything possible to make your purchase and experience with Oneida Air Systems a good one!

**Customer Service Dept.**

**1-866-387-8822 • [support@oneida-air.com](mailto:support@oneida-air.com)**

1001 West Fayette Street, Syracuse, NY 13204 U.S.A.

Copyright © 2021 Oneida Air Systems, Inc.