



The Industry Leader in Dust Collection

OWNER'S MANUAL



Mini-Gorilla

110V / 220V

XXPM010100H

XXPM010100H220

U.S. Patent: # #7824457,
#8377160, #8491686,
#8496719, #7937803



Table of Contents

System Start-Up Information	2
System Specifications	4
System Dimensions	5
System Contents	6
Assembly Instructions	8
Maintenance	14
Troubleshooting	15
FAQ	16
Recommended Accessories	18
Warranty Information	20
Notes	21

System Start-Up Information



Make sure to read and understand the installation and maintenance instructions as well as all recommended safety practices.

⚠ WARNING ⚠

1. Install ductwork completely before operating collector
 - a. Seal ductwork with silicone sealant or duct tape.
 - b. Have dust drum in place and sealed.
2. DO NOT operate Fan / Blower unless Fan Housing is attached to Cyclone body and Dust Drum is in place. Dust Drum and Cyclone must be in place and sealed or motor will overheat!
3. DO NOT operate without filter in place. Fan blade can cause serious injury.
4. The Direct Drive Fan / Blower makes the system top heavy! Use extreme care when setting the unit up! It is recommended that at least two people lift the system up.
5. Check amperage draw on motor with all gates open. Current draw should not exceed maximum motor amperage as stated on motor plate. (Oneida Air Systems is not responsible for damage to motors caused by improper installation, wiring or failure to follow these directions).
6. This equipment incorporates parts such as switches, motors or the like that tend to produce arcs or sparks that can cause an explosion.
7. To reduce the risk of Electric Shock, DO NOT use outdoors or on wet surfaces.
8. Exhaust air should not be vented into a wall, a ceiling, or a concealed space of a building.
9. To reduce the risk of injury from moving parts - unplug BEFORE servicing.

⚠ FIRE HAZARDS ⚠

1. Wood shaping and cutting processes generate wood chips, shavings and dust. These materials are considered combustible. Air borne wood dust below 420 microns in size (0.17 of an inch) in certain concentration ranges when ignited can deflagrate (burn quickly). An ignition source such as a spark or ember can ignite a dust mixture resulting in an expanding flame front, which can cause an explosion if tightly contained. A disturbance that raises a cloud of accumulated fine dust can raise additional dust clouds, which can cause a series of explosions that can level an entire building. Until this type of fire has been witnessed, it is difficult to believe the devastation. This type of fire is rare but worth safeguarding against.
2. The best way to avoid a wood shop fire is to keep the shop clean. A shop ankle deep in dust with layers of fine dust everywhere is an accident waiting to happen. A good dust collection system reduces overall fire hazards but also adds new concerns. A fire hazard is still present. Combustible material is now in the dust collector and storage container.
3. The following points are worth heeding:
 - a. It is the buyer's responsibility to follow all applicable federal, state, local, OSHA, NFPA, or authorities having jurisdiction codes and regulations when installing and operating this dust collector.
 - b. Fire Marshals may want the unit located outside of the building. If the collector is located inside the facility, controls such as spark detection, suppression, or explosion venting may be required.
 - c. Most local jurisdictions consult or adopt NFPA (National Fire Protection Agency) codes. However, other codes may apply. Local codes may vary from jurisdiction to jurisdiction.

System Start-Up Information (Continued)

- d. NFPA664 Code book, “Standard for the Prevention of Fires and Explosions in Wood Processing and Woodworking Facilities”, applies to woodworking operations that occupy areas of more than 5,000 sq. ft. or to areas where dust producing equipment requires an aggregate dust collection flow rate of more than 1,500 cfm (cubic feet per minute). This exempts some small operators from the NFPA code 664, but other codes may apply in your jurisdiction. Consult your local Fire Marshal for help. Additional information can be found in NFPA Code Book 664.
4. The customer assumes the responsibility for contacting their insurance underwriter regarding specific application requirements of explosion venting or if additional fire protection and safety equipment may be required.
5. DO NOT use this product to collect other types of flammable dust or flammable vapors! - Fire or explosion may occur!
6. NEVER collect sparks from a bench grinder into a wood dust collector.
7. NEVER introduce sparks or sources of ignition into the dust collector.
8. Personnel should be kept at least 20 ft. away from unit.
9. Check dust bin frequently and before leaving the shop for smoldering material.
10. Keep portable fire extinguishers handy.
 - a. The ABC type (dry chemical) is generally a good choice for small wood shops.
 - b. Additional information on portable extinguishers can be found in NFPA 10 (Standard for Portable Fire Extinguishers).
11. Be especially careful with sanding units. They can produce concentrations of dust in the combustible range. Make certain enough air volume is at the suction point to capture all the particulate generated.
12. This high air volume will dilute the mixture below the lower limit of flammability. Be careful not to generate sparks into the sanding dust.
13. Empty dust bin and clean filter often, especially when sanding.
14. DO NOT overload woodworking equipment, especially sanders. Excessive frictional heat can spontaneously ignite dust.
15. Sparks can be generated in several ways:
 - a. High speed sanders and abrasive planers may strike foreign material.
 - b. Saws and edgers may strike foreign material and create a red-hot metal fragment.
 - c. Knots in hardwood can create frictional sparks.
 - d. Trapped metal when drawn into the collector can spark against ductwork.
 - e. Check wood stock for old nails and screws which can create red hot metal fragments.
16. Avoid using excessively large wood waste bins.
17. ALWAYS check storage bins for smoldering material before leaving for the day.
18. Electrically ground all equipment and ducting. Static sparks can ignite wood dust. (Avoid using PVC drain pipe.)
19. DO NOT allow accumulation of layers of fine dust on horizontal surfaces (especially overhead lights, electrical boxes and fuse panels which can ignite dust.)
20. UNPLUG UNIT BEFORE SERVICING OR CLEANING

OAS Customer Service Dept.

1-866-387-8822 • support@oneida-air.com

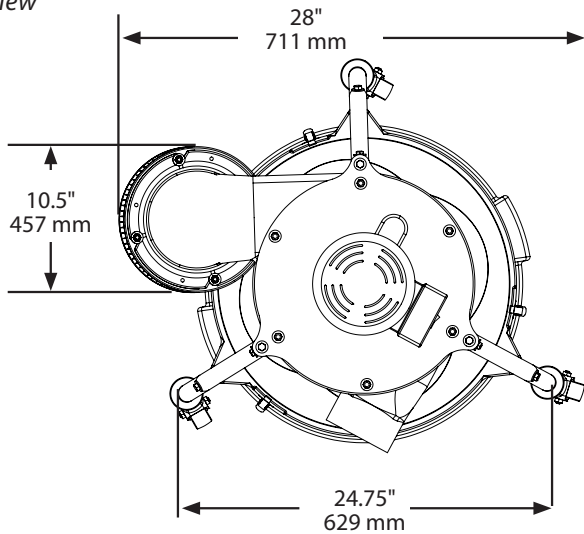
System Specifications

OPERATION	
Fan Rating (with Cyclone & Filter)	583 CFM at 2" SP (990.5 m ³ /hr at 51 mmH ₂ O)
Maximum Suction Rating	9" H ₂ O (229mmH ₂ O)
MOTOR AND ELECTRICAL	
Motor Type	U.S. Made TEFC Motor
Motor Insulation	Class F
Motor Service Factor	1.15
Horsepower	1.5 HP (1.1 kW)
Motor Speed	3,450 RPM
Phase	Single-Phase (1ph)
Voltage	110V / 220V
Cycle	60Hz
Listed FLA	110v: 16A/ 220v: 8A
On/Off Switch	Rocker Switch
Power Cord	20 ft (6 m)
Power Connector	110v: NEMA 5-20 / 220v: NEMA 6-20
Recommended Circuit Size	20A
Recommended Circuit Type	HACR
Sound Emission	80.5 dBA @ 10 ft (3m)
IMPELLER	
Size	13" (330 mm)
Material	Single-piece, backward inclined, non-sparking/non-ferrous
CARTRIDGE FILTER	
Filter Media Type	G.E. H12 HEPA
Filter Efficiency	99.97% @ 0.3 microns
Filter Surface Area	40 Sq. Ft. (3.7 sq m)
SYSTEM DIMENSIONS AND CONSTRUCTION	
Barrel/Cyclone Body	Molded Static Conductive Resin
Inlet	5" (127 mm) Outer Diameter
Overall Height	64.25" (1,632 mm)
Overall Weight	85 lbs (38.5 kg)

System Dimensions

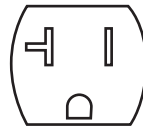
Nominal dimensions shown. Dimensions subject to slight variations in manufacturing.

Top View

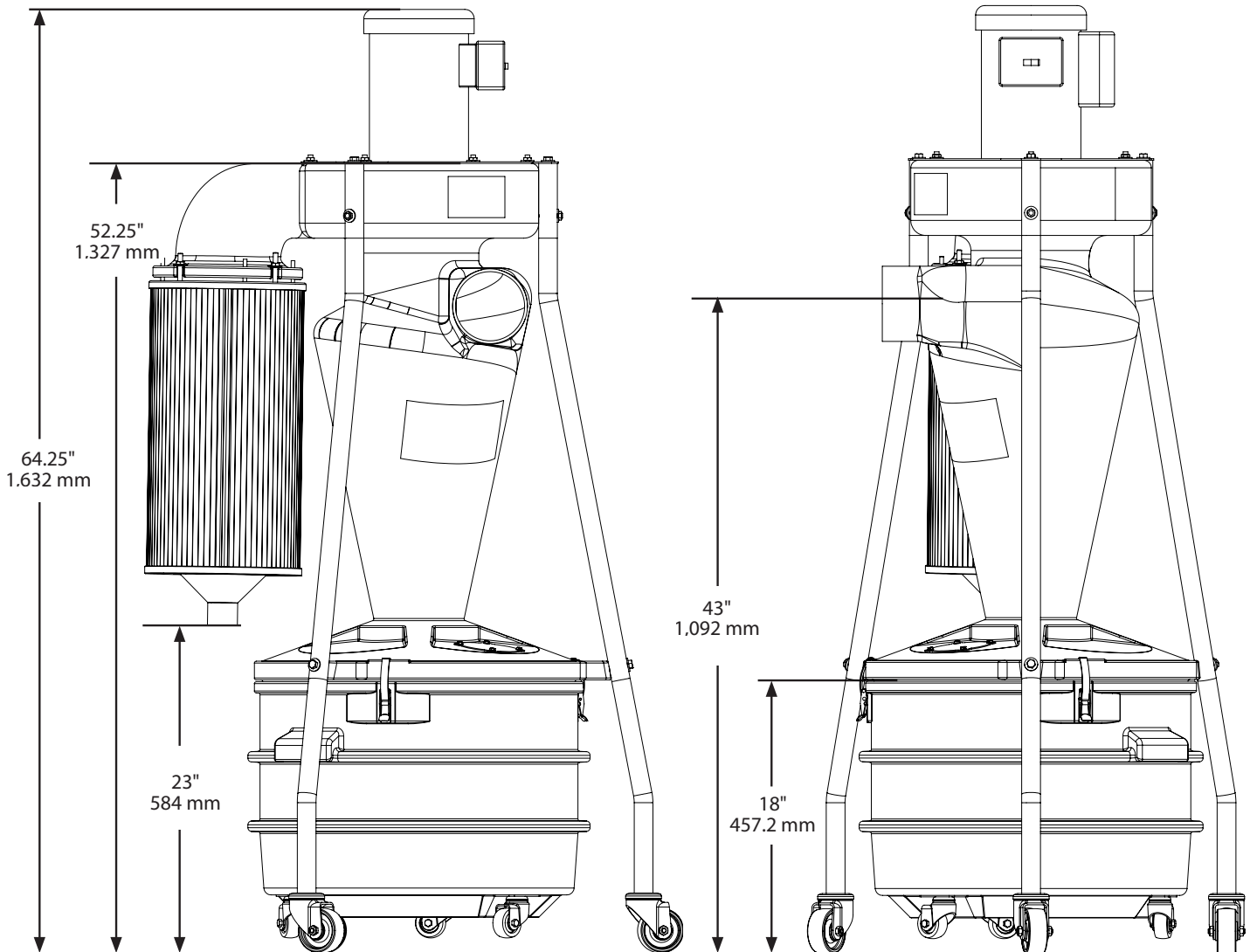
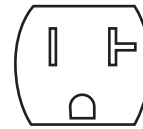


The Mini-Gorilla requires a 20 Amp outlet receptacle to be installed by a licensed electrician. See below outlet receptacles needed based on the voltage of your unit.

110V



220V



System Contents



If you cannot find an item on the list, examine the packaging materials very carefully. Certain components have been pre-installed.* There may be hardware leftover.

ID	Part number	Part description	Qty
A	BXI001605C BXI001604C	Motor Assembly 1.5 HP 110V Motor Assembly 1.5 HP 220V	1
B	FCS101935HFA	10.5" x 19.5" HEPA Cartridge Filter with molded sound absorber	1
C	SXM010100C	Cyclone and Drum Assembly	1
C1	SMM010100	Molded Cyclone and Drum	1
C2*	AFL990001	Latches	3
C3*	AFS501032	10-32 1/2" Phillips Pan Head Screws	10
C4*	AFT901032	10-32 Nylock Nut	1
C5*	AFW200000	#10 Flat Washer	10
C6*	RHL000604	Drum Window	1
C7*	RGZ025050	Gasket	6 ft.
C8	STG491616	Leg Assembly	3
C9	AHX001605B	Mini Gorilla Hardware Kit	1
C9A	VAB363602	22 Gal. Heavy-Duty Plastic Liner Bags	2
C9B	VRV050500	1/2" ID Vinyl Tubing	5 ft.
C9C	RGZ025050	Gasket	6 ft.
C9D	ABF500000	1/2" Straight Fitting	2
C9E	AFW180508	5/8" Rubber Washer	2
C9F	RCP060000	PVC Tube Cap For Inlet Cover	1
C9G	RHC000007	3" Casters with 5/16-18 x 1" Stems	3
C9H	AFB025175	1/4"-20 x 1 3/4" Carriage Bolt	3

ID	Part number	Part description	Qty
C9I	AFW025000	1/4" Flat Washer	3
C9J	AFT000005	1/4" Whiz-Lock Nut	3
C9K	AFB155195	5/16-18 x 2" Hex Head Bolt	3
C9L	AFW180000	5/16" Flat Washer	3
C9M	RHC000000	2" Drum Casters	3
C9N	AFS015920	1/4"-20 x 3/4" Hex Head Bolt	6
C9O	AFW180516	5/16" Rubber Washer	6
C9P	AFW025000	1/4" Flat Washer	6
C9Q	AFT000005	1/4" Whiz-Lock Nut	6
C9R**	AFT051618	5/16-18" U-Spring Nut	8
C9S	AFB155190	5/16-18 x 1" Hex Head Bolt	9
C9T	AFW180000	5/16" Flat Washer	9
C9U	ACB360000	1/2" Turn-Key Band Clamp	1
C9V	RCP101935	Filter Outlet Cap	1
C9W	AFW180000	5/16" Flat Washer	4
C9X	AFT900006	1/4"-20 Nylock Nut	4

Please unpack the parts carefully and confirm you have received each item listed here.

**Some components are pre-installed at the factory and are listed here for your convenience.*

***The U-Spring Nuts come in a pack of eight, but you will only need six for your installation.*

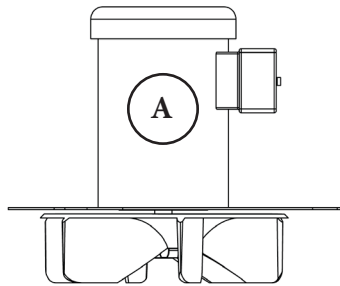
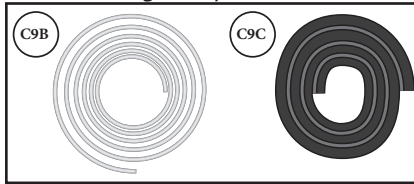
You will need the following:

- 7/16" Wrench
- 7/16" Socket Wrench
- 1/2" Wrench
- 1/2" Socket Wrench
- Small Hammer
- Phillips Head Screwdriver
- Flat-head Screwdriver
- Razor Blade
- Channel Lock Pliers+

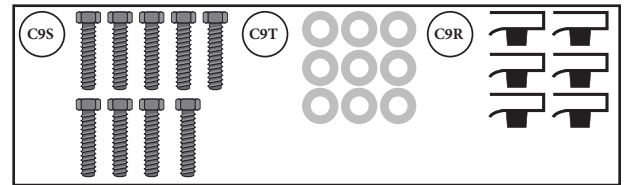
+The pliers are optional and are recommended for ease of installation.

System Contents (Continued)

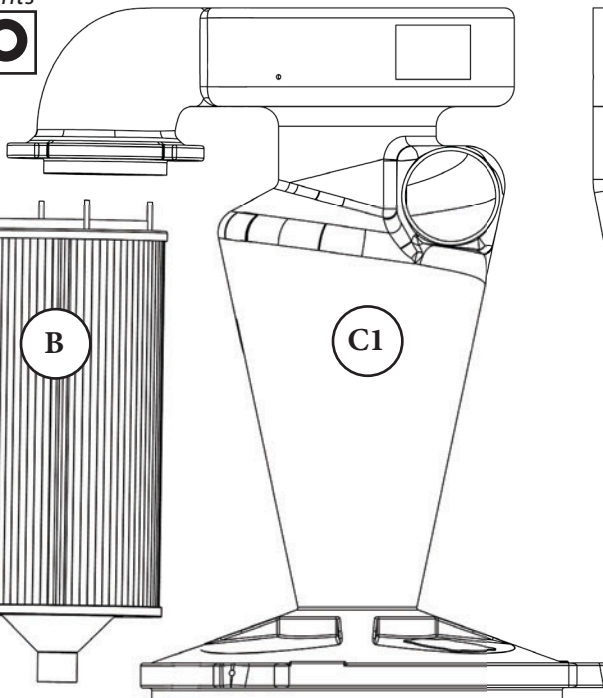
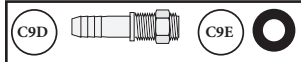
Gasket & Bag Components



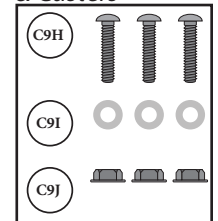
Motor Attachment Hardware



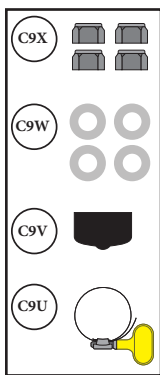
Gasket & Bag Components



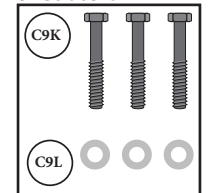
Leg Hardware & Casters



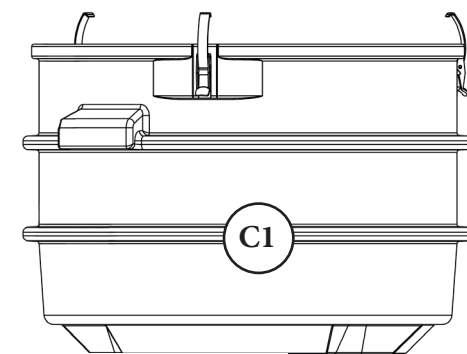
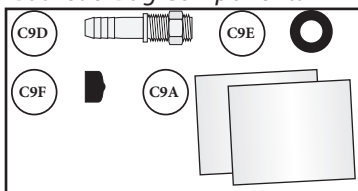
Filter Attachment Hardware



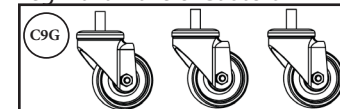
Leg Hardware & Casters



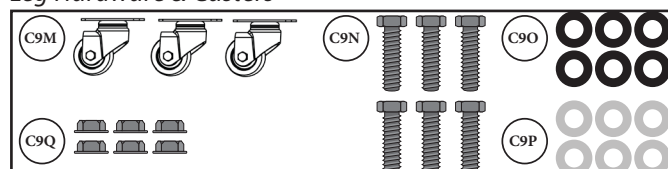
Gasket & Bag Components



Leg Hardware & Casters



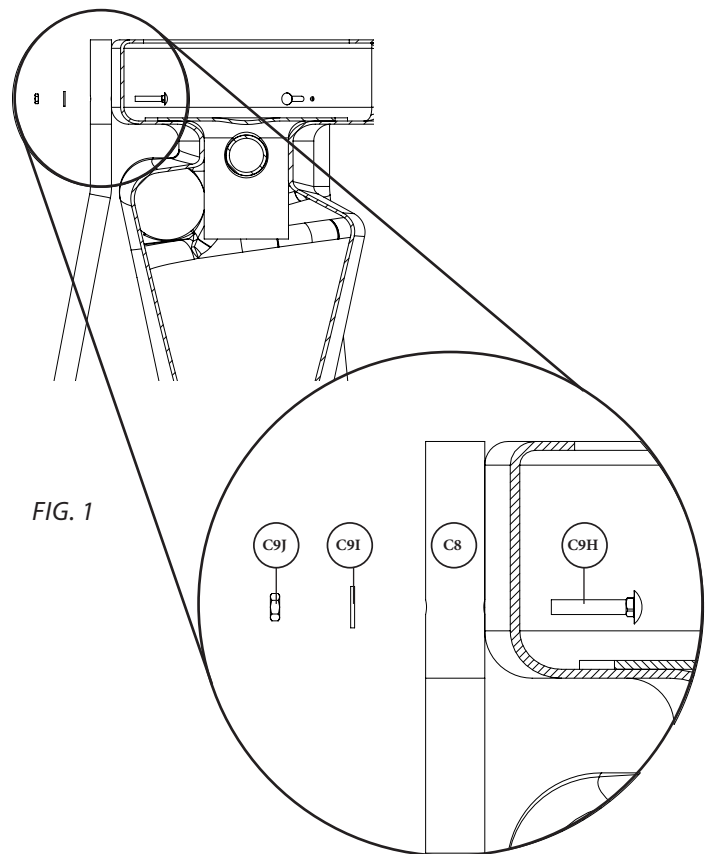
Leg Hardware & Casters



Assembly Instructions

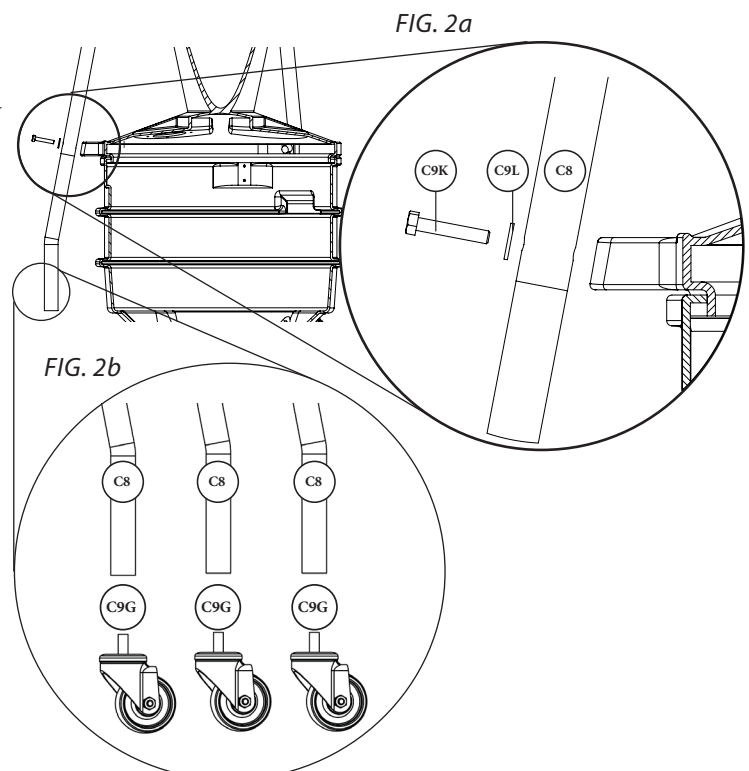
- 1 Push three Carriage Bolts (C9H) through the inside wall of the fan housing section of the molded cone. Thread the top hole of the Legs (C8) over the bolt and secure with a 1/4" Flat Washer (C9I) and 1/4" Whiz-Lock Nut (C9J). Finger tighten. [FIG. 1]

Note: The top of the leg is indicated by a hole located 3.5" from the end. The bolt's square shank must go through the round housing hole. For ease of assembly, tighten the nut on the carriage bolt without the washer - this will pull the square shank through the round housing hole. Once the carriage bolt is fed through the leg's hole, remove the nut. Secure in place with the washer and nut.



- 2 Secure each Leg (C8) to the threaded inserts on the lid using three 5/16" Flat Washers (C9L) and three 5/16" x 2" Hex Head Bolts (C9K). [FIG. 2a] Secure Stem Casters (C9G) to the threaded insert on the bottom of the legs. Finger tighten. [FIG. 2b]

Note: For ease of assembly, we recommend channel lock pliers to tighten the casters.

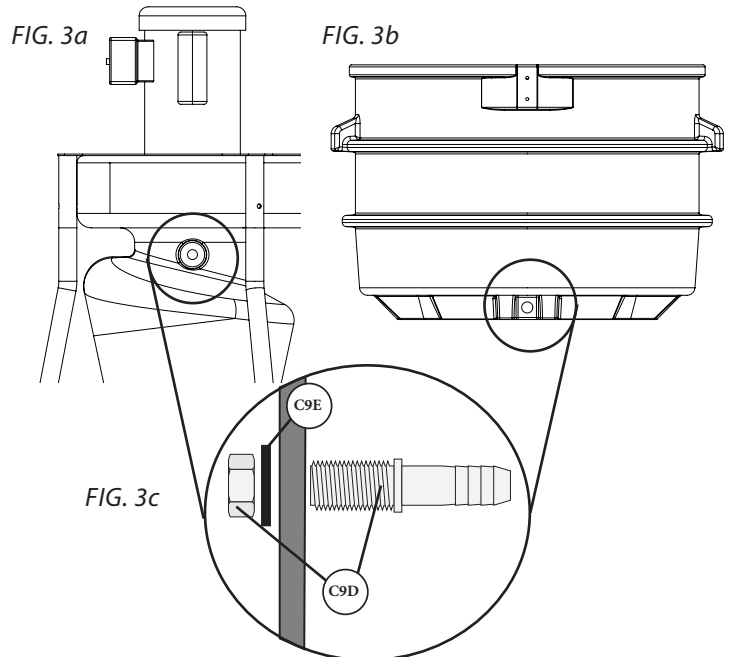


Assembly Instructions (Continued)

3

Install Straight Fittings (C9D) into the recessed holes under the fan housing and near the bottom of the drum. [FIG. 3a] [FIG. 3b] Secure in place using the fitting's nut on the inside; using a Rubber Washer (C9E) between the nut and the inner wall. [FIG. 3c]

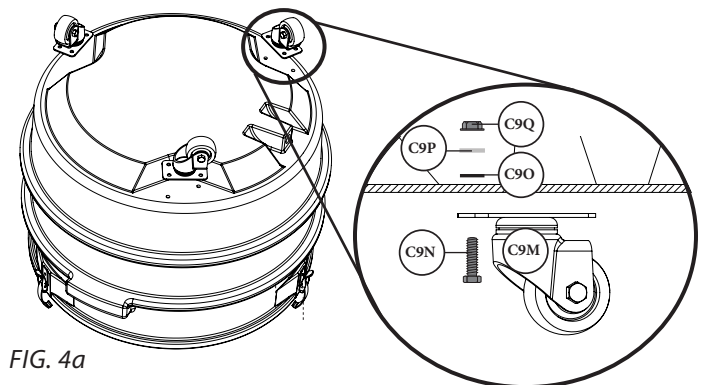
Note: For ease of assembly, when installing to the bottom of the drum, we recommend to wedge a flat screwdriver between the Straight Fitting (C9D) and the inner wall to secure it in place when securing the nut.



4

Install each of the three Drum Casters (C9M) to the drum using two 1/4" Hex Head Bolts (C9N), two Rubber Washers (C9O), two 1/4" Flat Washers (C9P), and two 1/4" Whiz-Lock Nuts (C9Q) as shown in [FIG. 4]. Use the bolt holes on opposing sides of the caster plate as shown in [FIG 4b]

Note: Be sure to use the rubber washer under the steel washers to assure an airtight seal. It is very important that there are no leaks.

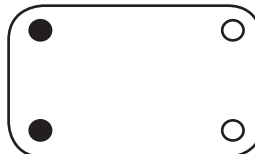


✓ **CORRECT**

FIG. 4b



✗ **INCORRECT**



✗ **INCORRECT**



Assembly Instructions (Continued)

- 5** Align the legs so that they are square and even with the drum and body. [FIG. 5]

Note: Hardware attaching the Legs (C8) to the Molded cyclone and Drum (C1) should be finger tightened to help align the Motor Assembly (A) in Step 10.

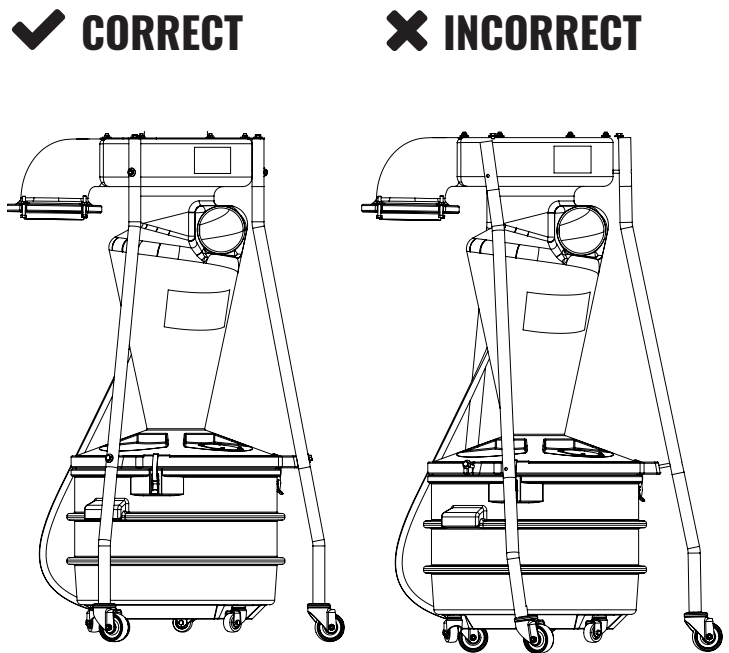


FIG. 5

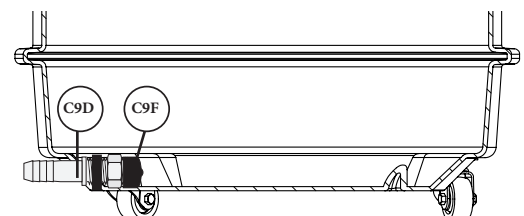
- 6** Insert a Drum Liner Bag (C9A) into the Drum, making sure it fully expands against the sides and the bottom of the drum. The top edges of the bag should fold out and over the drum's upper rim. [FIG. 6a]

Note: If you do not want to use bags you MUST use the Cap (C9F) to close off the fitting inside the drum. [FIG. 6b]

FIG. 6a

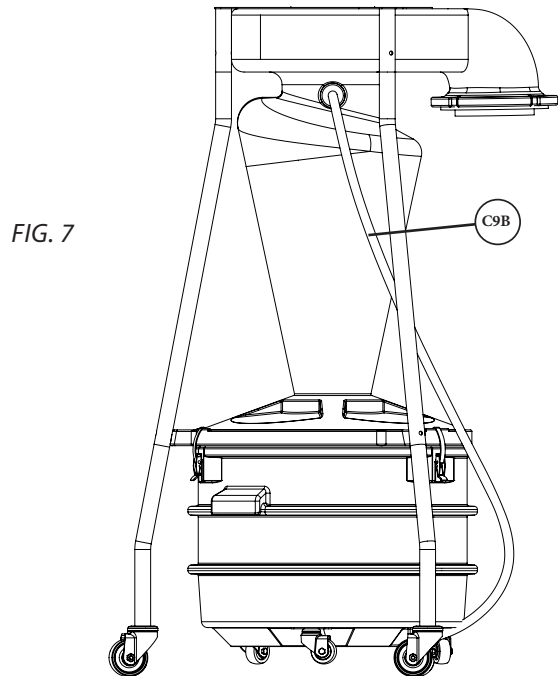


FIG. 6b



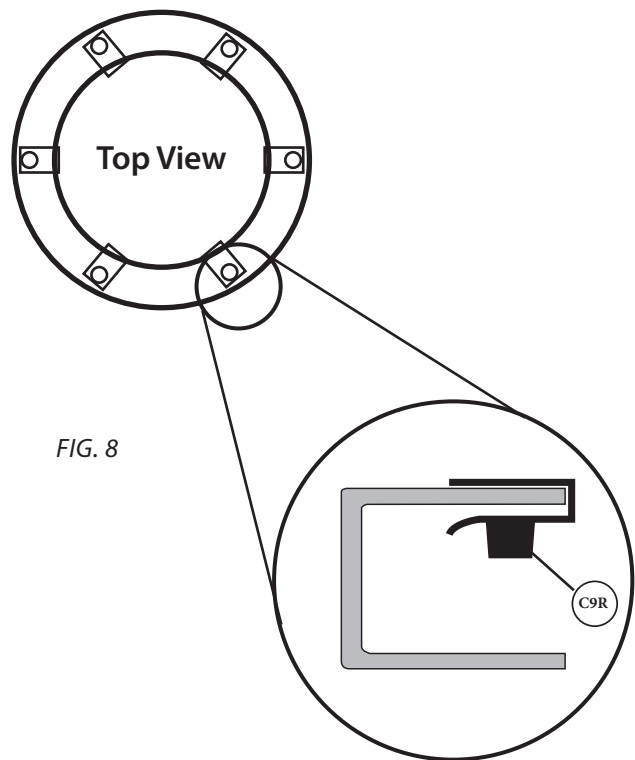
Assembly Instructions (Continued)

- 7 Latch the Drum to the cone assembly and connect the Vinyl Tubing (C9B) onto both Straight Fittings (C9D). Push tubing on until all barbs are covered. [FIG. 7]



- 8 Tap the U-Spring Nuts (C9R) onto each of the holes around the circle of the Fan Housing with a ball peen hammer. [FIG. 8]

Note: Make Sure the U-Spring Nut (C9R) is pushed all the way on by checking that the bolt holes are in alignment with the clip holes and installed in the correct orientation. Otherwise you will not get the seal needed for complete dust collection! There will be two leftover U-Spring Nuts that are not needed for the installation.



Assembly Instructions (Continued)

- 9 Apply the Gasket (C9C) to the motor plate as shown in [FIG 9], making sure that there is no gap where the ends meet.

Note: Dust collection systems cannot operate effectively if there isn't a complete seal. There must be NO air leaks.

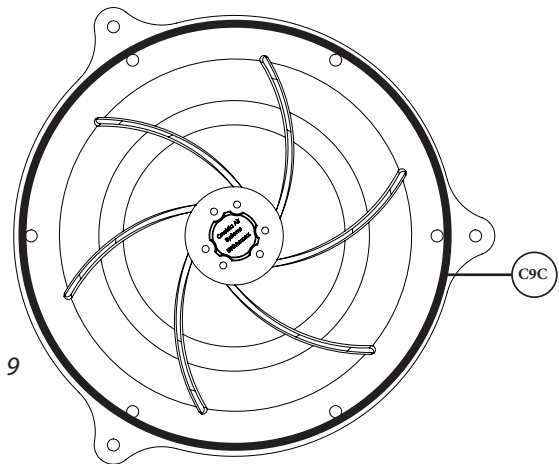


FIG. 9



The motor assembly is very heavy and cumbersome; Be sure to have adequate help to lift the motor assembly up!

- 10 Carefully lift the Motor Assembly (A) on top of the unit and align the motor plate holes with the fan housing holes and the threaded inserts on top of the legs [FIG. 10]. Thread and tighten the nine 5/16" x 1" Hex Head Bolts (C9S) and nine 5/16" Flat Washers (C9T).

Tighten all of the hardware; this includes the pre-installed parts used on the Drum Latches (C2) and the Drum Window (C6)

Note: If U-Spring Nuts (C9R) don't align with the motor plate holes, use a screwdriver to adjust misalignment. Hand tighten first and then tighten down.

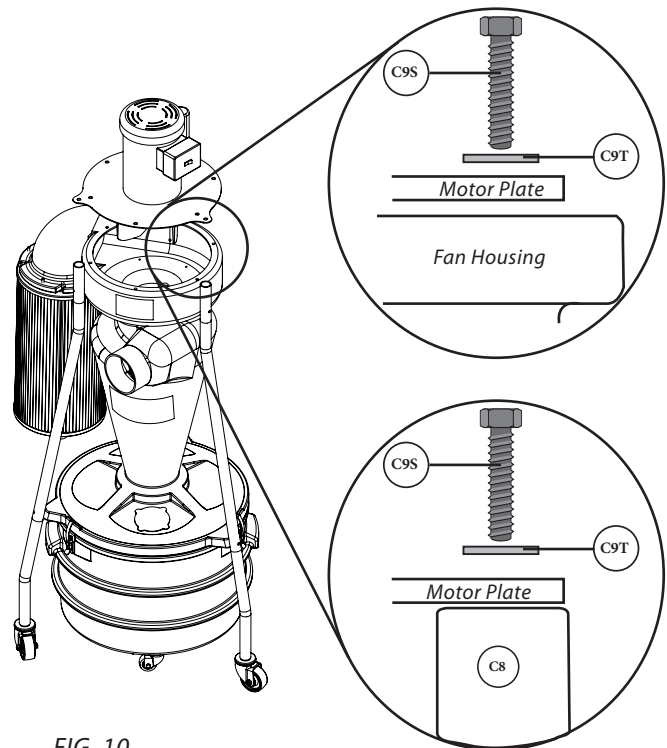


FIG. 10

Assembly Instructions (Continued)

11

Lift the Filter (B) up to the plenum elbow, slotting the filter's bolts into the four grooves, shown in [FIG. 11a]. Secure in place with four 5/16" Flat Washers (C9W) and four Nylock Nuts (C9X). [FIG. 11b]

Note: DO NOT overtighten.

FIG. 11a

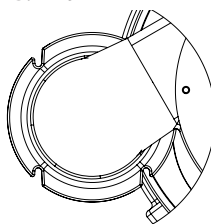
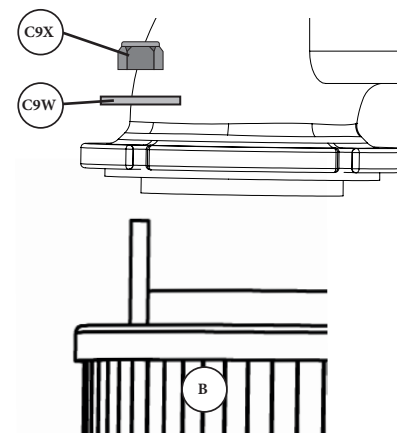
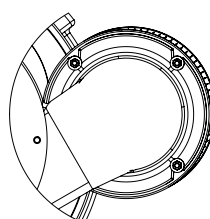


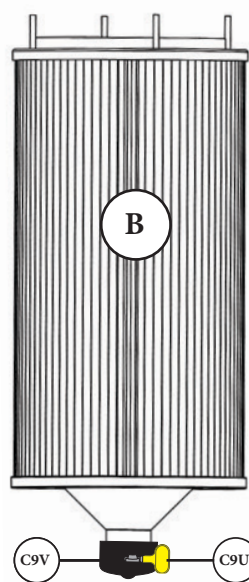
FIG. 11b



12

Place Filter Cap (C9V) onto the bottom port of the Filter (B) and secure in place using Band Clamp (C9U).

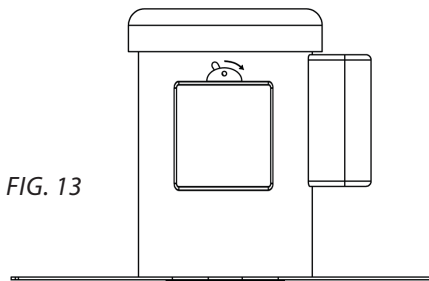
FIG. 12



13

Installation is complete! Plug in your collector and turn on the rocker switch mounted on the motor. [FIG. 13]

FIG. 13



Maintenance

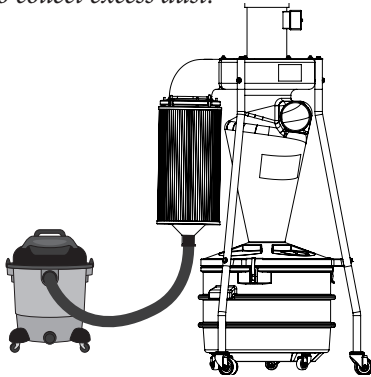


UNPLUG YOUR UNIT BEFORE SERVICING OR CLEANING. KEEP THE TOP VENTS IN THE COWLING CLEAN. THESE ARE FOR BOTH EXHAUST AND INCOMING COOLING AIR FOR THE MOTOR.

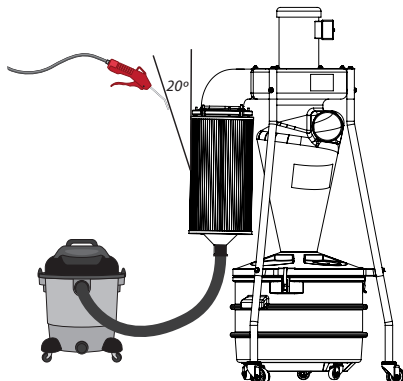
Cleaning the filter

Proper filter cleaning should not be neglected as a dirty filter can significantly affect your dust collector's performance and the overall lifespan of your filter.

1. Wear a dust mask and eye protection.
2. Turn off and unplug the dust collector and wait for the fan blower to come to a complete stop and for the dust to settle.
3. Remove the Filter Cap (C9V) from the bottom of the filter. Attach your wet/dry vacuum's hose to the outlet. Turn on your wet/dry vacuum.
Note: The filter's outlet measures 1.9" ID and 2.1" OD; You may need an adapter depending on your hose. If you don't have a shop vacuum available you can clamp a bag over the outlet to collect excess dust.



4. While the wet/dry vacuum is running. Use a hand-held, compressed air nozzle with a pressure between 30 to 60 PSI to blast air along the filter's exterior pleating. Hold the air nozzle at a 20 degree angle and at least 6" away from the filter; closer blasts may damage the filter material. Direct air out and away from anyone in the area. Do not use this method when any hazardous material has been vacuumed up.



5. Check to make sure filter is in good condition with no torn media or cracks or tears in the seal. A broken filter can leak material into the motor and cause severe damage! You cannot operate the system without a proper filter in place. (See Accessories page for the replacement filter part.) Operating without a sufficient filter will cause severe damage to the motor and will void the warranty!
Note: To help see damage from the outside, a flashlight can be used.

Emptying the Drum

When first using the dust collector, check the drum window regularly to get an idea of how often it needs to be emptied. If the drum becomes overfilled, the dust will be sucked into the collector and into the filter. To clean the view window **ONLY** use a clean, soft cloth. **NEVER** use solvents. Using a flashlight will make viewing the dust levels easier.

1. Wear a dust mask and eye protection.
2. Turn off the dust collector and wait for the fan blower to come to a complete stop and for the dust to settle before unlatching the drum from the cyclone body.
3. Dispose of waste safely and properly.
4. Replacement bags should be 36" x 36" and at least 1.5 mils thick. See Accessories page for replacement bags needed for your system. When you are not using a bag in your drum then you must use the Cap (C9F).

Troubleshooting

PROBLEM	CAUSE	SOLUTION
Motor Overheating/System Tripping (The motor's internal circuit breaker will trip if the motor is overheating)	Air leaks between the dust collector and dust bin	<ol style="list-style-type: none"> 1. The lid of the dust drum must be in place, have a foam seal, and be well seated when operating the dust collector 2. Check for holes or leaks in the dust barrel 3. Check the vinyl hose connection and the filter cap.
	Motor not properly wired	<ol style="list-style-type: none"> 1. Check wire connections 2. Check motor rotation 3. Check breaker box to make sure power supply is correct for motor 4. Ensure the unit is not installed on a GFCI outlet/breaker. We recommend a 20A HACR-type circuit breaker.
	Circuit breaker tripped	<ol style="list-style-type: none"> 1. The Mini-Gorilla draws approximately 15 amps. Make sure your wiring can accommodate this load. Never compromise the grounding pin on any plug. 2. Check for clogs or debris jamming the fan blade. 3. Ensure the unit is not installed on a GFCI outlet/breaker. We recommend a 20A HACR-type circuit breaker.
Poor dust pick-up at Tools	System and ductwork connections	<ol style="list-style-type: none"> 1. Check length of duct runs, duct diameters, and hood design compared to ductwork design guidance 2. Make sure all connections to the system are sealed. Large air losses will occur even through small cracks in the ductwork. Use silicone, duct tape or duct mastic compound as a sealant. 3. Check for air leaks between collector and dust drum. 4. Be sure that your filter is clean.
Filter Clogging	Large Chips Clogging the Filter	<ol style="list-style-type: none"> 1. Check for a leak in the dust bin or lid. 2. Make sure dust bin has not over filled. Dust bin should be emptied before the dust reaches top of container.
	Fine dust clogging the filter	<ol style="list-style-type: none"> 1. Air flow to the collector may be restricted. The collector needs the equivalent of at least a 4" diameter cross-section open to allow adequate air volume and speed for pre-separation in the cyclone stage of the collector. If you are using a woodworking machine with only one 2" diameter dust port, partially open another blast gate to compensate. 2. Heavy sanding with a drum sander or fine grit paper will cause the pleated filter media to bind sooner than with larger size dust. Clean filter more often with compressed air.



If you continue to experience difficulty with your dust collector, call Oneida Air Systems' Customer Service Department at 1-866-387-8822 or email support@oneida-air.com.

FAQ

How is the Mini Gorilla filter cleaned? I don't see the typical hand crank.

The use of hand cranks that "beat" the filter can damage the filter's pleating material overtime, so our systems are not built with such systems. Please see the Maintenance section titled Cleaning the filter.

Can this be used for wet applications?

No. This system is designed for collecting dry materials only.

What dust can be collected?

Oneida Air Systems' dust collectors are designed and tested for wood and wood dust. They can and have been be used effectively for various other dusts and chips such as drywall dust, paper dust, agricultural dust, metal chips and other forms of debris. The customer is however, cautioned that some common materials when cut, ground or processed by machinery may become very dangerous: highly toxic, flammable, or deflagrable and explosive and they should therefore ensure that you use your particular use of a dust collection system in accordance to national, state, local, NFPA, OSHA and all other applicable codes.

Can I wall mount my Mini Gorilla to the wall?

Currently, we do not have any wall mount solution available.

Is this product compatible with Quick-Clamp Duct?

Yes, but you will need both a 5" Female Hose Quick Connect (DQF050000) and a Machine Adapter (GAM050000) into the dust collector's inlet. The Machine adapters are smaller on the raw end than traditional ducting. A 5" Quick-Clamp Duct Machine Adapter will measure ~4.9" O.D. on the raw end.

How do I connect the Mini Gorilla to my tools?

The Mini-Gorilla's inlet measures 5" on the outer diameter, making it ideal for accepting raw (uncrimped) ductwork fittings over the inlet such as reducers and quick-connects. Crimped ductwork will not usually fit into the inlet but can be done when necessary and secured in place with foil tape. Flex hose can also be pulled over the inlet but will generally be a tight fit.

What size tool ports will this work with?

The Mini Gorilla is designed for use with tools that have a single 4" or 5" dust collection port. We do not recommend the Mini Gorilla dust collector be used with ports smaller than 4" in diameter.

FAQ (Continued)

How many tools can I collect from simultaneously?

We recommend to run one tool with a 4" or 5" port at a time. If you have multiple tools connect to your system, close off the ports to unused tools with blast gates when they are not in use.

Do you have a ductwork kit that includes everything I need to get started?

Yes, we have a Mini-Gorilla Quick-Start Ductwork Kit (KDZ010100) that includes:

- a. DHF051000: Ten feet of 5" flex hose
- b. ACB060000: Two 3-6" clamps
- c. DZX990504: One 5-4" reducer crimped on the 5" end.

Can I connect Flex Hose directly to the inlet?

Yes, it will be a secure and firm fit.

I'm having trouble attaching flex hose to the inlet, do you have any tricks?

Start with the cut end of the hose and pull the hose ends up little by little to work the hose onto the cyclone's discharge. Pliers can be used to grab the reinforcing wire and aid in pulling the hose over the opening. Using heat (such as a hair dryer) can be gently applied to the molded inlet to make the resin more malleable and allow for easier hose fittings - exercise caution when heat-treating so as not to damage the system.

What's the furthest length and diameter of hose that I can run?

You can run up to twenty-five feet of five inch flex hose.

Recommended Accessories



10.5" x 19.5" HEPA Cartridge Filter with FlameGuard

#FCS101935HF

- Independently tested G.E. Certified H12 HEPA filter media.
- Wide-spaced pleated filters with teflon-like coating for quick and easy dust removal.
- Equipped with patented FlameGuard™ arrestor mesh for added safety.



22 Gallon Heavy-Duty Plastic Liner Bag

#VAB363602

- Lines the inside of medium sized, 22 gallon containers for fast and simple waste disposal.
- Heavy thickness protects against tearing from wood chips or other sharp debris.
- 36"H x 36" Dia.



Dust Sentry Bin Level Indicator

#AXB999110B

- High intensity strobe light can be mounted anywhere in your shop!
- Low voltage - Works on standard 110V power
- User controlled fill-level can be adjusted for distances 1" to 20" from the lid



iVAC Pro Tool Plus Automatic Power Sensor

#STZ212301

- Up to 8 tool sensors can be synced to the same switch.
- Transmits radio frequency signal to the iVAC Pro Switch from up to 40' away.
- Multiple operating modes for automatic or direct manual control of the system.

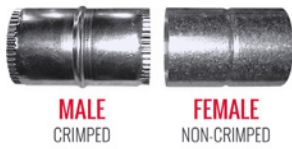


115V iVAC Pro Automated Dust Control Switch

#ARS115200

- Detects when your power tools are on and automatically turns on the dust collector for you!
- Includes 1 Remote Control with belt-clip.
- Switch receives signals from up to 40' away in any direction.

Recommended Accessories (Continued)



5" Hose Quick Connect Adapter Kit

#DQK050000

- Includes both the crimped and non-crimped quick release flex-hose adapter fittings.
- Made from heavy-gauge, galvanized steel.
- Perfect when using a single connection to switch between multiple tools.



5" - 4" Reducer

#DRL050400

- Useful for reducing the diameter of your ductwork connecting to your tools and/or flex hose.
- Raw ends can be crimped if specified by customer.
- Ends measure 2" deep.



4" - 2.5" Reducer

#DRL040212

- Useful for reducing the diameter of your ductwork connecting to your tools and/or flex hose.
- Tapered for high airflow efficiency.
- Heavy wall thickness.



Flex Hose 5" Diameter by 15' Long

#DHF051500 (also available in 5', 10' and 25' lengths)

- Highly flexible hose made from abrasion resistant PVC material.
- Reinforced with steel wire-helix for heavy-duty usage.
- Transparent hose makes it easy to spot and clear potential blockages.



3"-6" Quick-Release Hose Clamp

#ACB060000

- Secure flex-hose fittings over the ports on your tools and dust collector.
- They easily adjust in size to slip over the hose and can then be tightened.
- Each clamp features a quick-release lock to simplify hose hookups with your tools.

Warranty Information

Limited Warranty – Activate online at oneida-air.com/warranty

Oneida Air Systems®, Inc. (OAS) warrants the products it manufactures for a period of 1 or more years, depending on the product, to the original purchaser from the date of purchase, unless otherwise specified. Items not manufactured by Oneida Air Systems are limited to their own manufacturer's warranties. All electrical items such as magnetic starters, remotes, sensors, pumps, bin sensors, bag grippers, etc. and accessories are limited to 90 days. Oneida Air Systems warrants that the product will be free from defects in materials and workmanship.

This is Oneida Air Systems' sole written warranty and any and all warranties that may be implied by law, including any merchantability or fitness, for any particular purpose, are hereby limited to the duration of this written warranty. Oneida Air Systems does not warrant or represent that the merchandise complies with the provisions of any law or acts unless the manufacturer so warrants. This warranty does not apply to defects due directly or indirectly to misuse, negligence, accidents, abuse, repairs, alterations, improper wiring or lack of maintenance. In no event shall Oneida Air Systems' liability under this warranty exceed the purchase price paid for the product and any legal actions brought against Oneida Air Systems shall be tried in the State of New York, County of Onondaga.

The buyer is cautioned to install and operate Dust Collectors in accordance with prescribed Federal, State, OSHA, NFPA, local codes and regulations. This equipment should be installed/wired by a licensed electrician following all applicable codes. Local codes can be significantly different from national codes. The customer assumes the responsibility for contacting their insurance underwriter with regard to specific application requirements of venting or if additional fire protection and safety equipment may be required. Oneida Air Systems shall in no event be liable for death, injuries to persons or property or for incidental, and contingent, special, or consequential damages arising from the use of our product.

Oneida Air Systems makes every effort to accurately represent our products and prices, however Oneida Air Systems reserves the right to make changes to products and prices at any time. As a manufacturer, Oneida Air Systems reserves the right to change product specifications at any time in an effort to achieve better quality products.



ONEIDA AIR SYSTEMS SHALL IN NO EVENT BE LIABLE FOR DEATH, INJURIES TO PERSONS OR PROPERTY OR FOR INCIDENTAL, AND CONTINGENT, SPECIAL, OR CONSEQUENTIAL DAMAGES ARISING FROM THE USE OF OUR PRODUCT.



SAFETY WARNING - PLEASE READ

Before Purchasing or Installing a dust collection system the buyer is cautioned to do so in accordance with prescribed Federal, State, Local, OSHA, NFPA, and any other applicable codes or regulations relating to the type of dust(s) you are collecting.

SOME TYPES OF DUST UNDER CERTAIN CONDITIONS HAVE THE POTENTIAL TO BE EXPLOSIVE.

Oneida Air Systems is not responsible for how the dust collector is used or installed. Dusts with deflagration or explosion risks, such as wood dust, may require additional safety equipment including but not limited to; venting, spark detection, suppression systems, back draft dampers or may require installation in an outside location or in a protected area away from personnel. The customer assumes the responsibility for contacting their insurance underwriter with regard to specific engineering controls or application requirements. (We suggest you reference NFPA 664, 654 and 68 codes for more information) Oneida Air Dust Collection Systems may not be suitable for some applications and are not designed to be used in explosive atmospheres. Oneida Air Systems equipment should only be installed and wired by a licensed electrician following all applicable local and national electrical codes.

Some dust created by power sanding, sawing, grinding, drilling, and other construction activities contains chemicals known to cause cancer, birth defects or other reproductive harm. Some examples of these chemicals are: Lead from lead-based paints; Crystalline silica from bricks, cement and other masonry products; Arsenic and chromium from chemically-treated lumber; etc.

Your risk from these exposures varies, depending on how often you do this type of work. To reduce your exposure to these chemicals, work in a well ventilated area, and work with approved safety equipment, such as those dust masks that are specially designed to filter out microscopic particles. Oneida Air Systems recommends using additional approved safety equipment such as an approved OSHA and NIOSH dust mask or respirator.

Oneida Air Systems makes every effort to accurately represent our products, specifications and prices; however Oneida Air Systems reserves the right to make changes to products and prices at any time. As a manufacturer, Oneida Air Systems reserves the right to change product designs and specifications at any time.



The **Industry Leader in Dust Collection**

Thank you for your business!

Regardless of where you purchased your system, if you have any questions or issues with missing / damaged parts, please call Oneida Air Systems first to let us help resolve your problem. We fully stand behind the quality of our product and place the utmost value on our customer's opinion.

We want to do everything possible to make your purchase and experience with Oneida Air Systems a good one!

Customer Service Dept.

1-866-387-8822 • support@oneida-air.com

1001 West Fayette Street, Syracuse, NY 13204 U.S.A.

Copyright © 2019 Oneida Air Systems, Inc.