



Molded Drum Dolly Instructions - SDD990000

For use with:

5 Gal. Plastic Pail / 10, 17, 30, 35, and 55 Gal. Steel Drum / 35 & 55 Gal. Fiber Drum

Limits of Use:

- Indoor use only
- Use only on level and even floors
- Temp. Range 0° F to 100° F
- Max. weight load is 150 lbs.
- For use with Oneida Air Systems™ products only
- *This Drum Dolly is not a toy. Keep out of reach of children.*

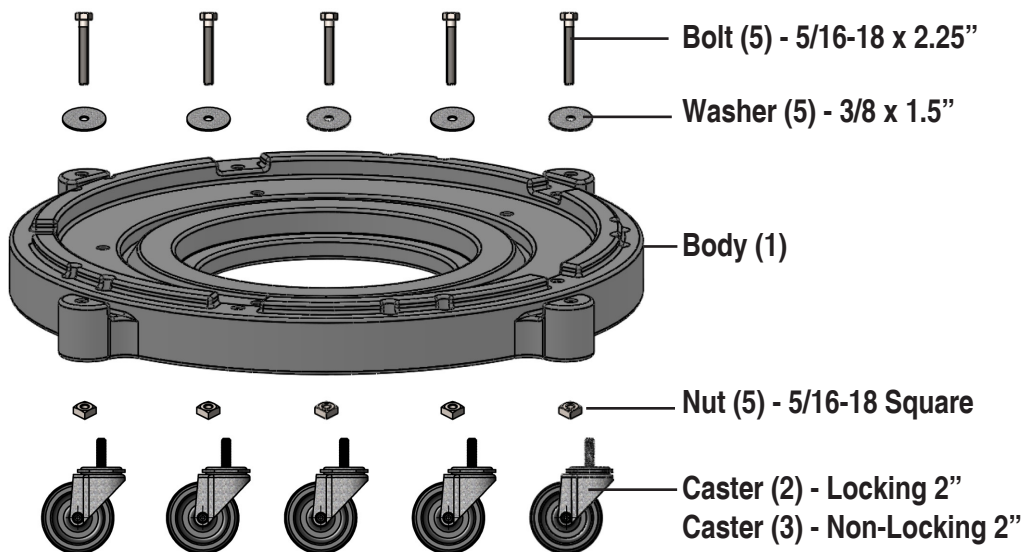

Optional Kit for 35 & 55 Gal. Fiber Drum -
AHX990000



Washer (4) - 5/16"

Bracket (4)

Tools required: 1/2" Wrench

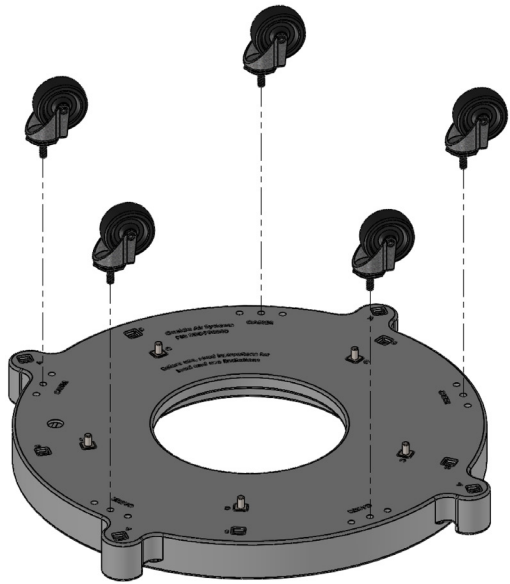

Non-Locking Casters

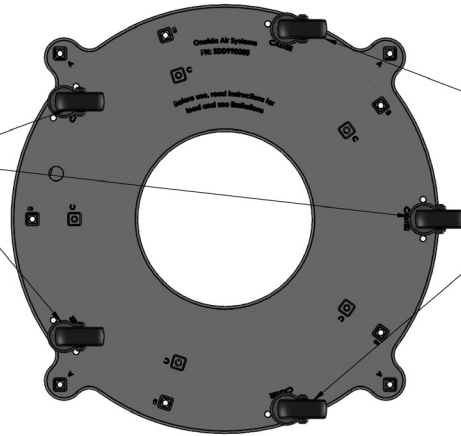

Locking Casters

- Unpack all items.
- Place molded dolly face down.
- Screw the 5 casters into holes marked "caster" as shown in diagram. Use pliers to tighten snugly, if it comes loose use thread locker.
- (FOR 5 GAL > PAIL) Simply place pail in center recess.

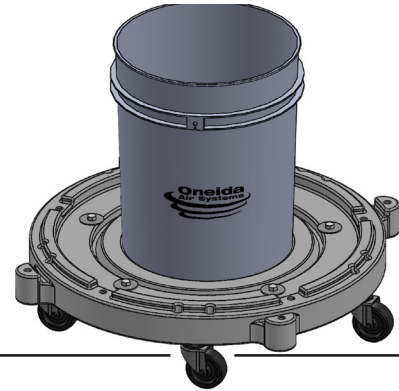

For 10, 17, 30, 35 & 55 Gal. Steel Drums:

For 35 & 55 Gal. Fiber Drums:

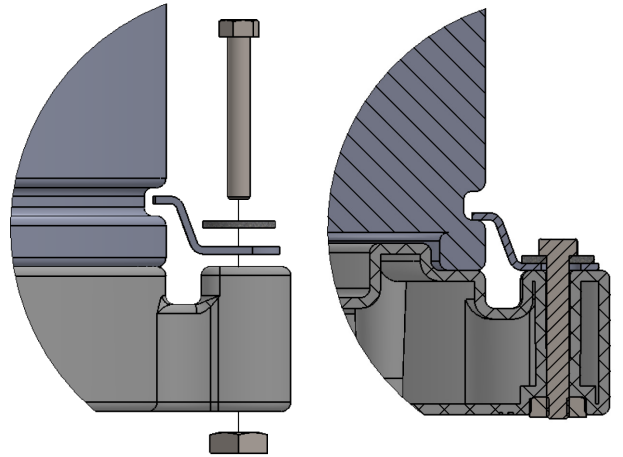
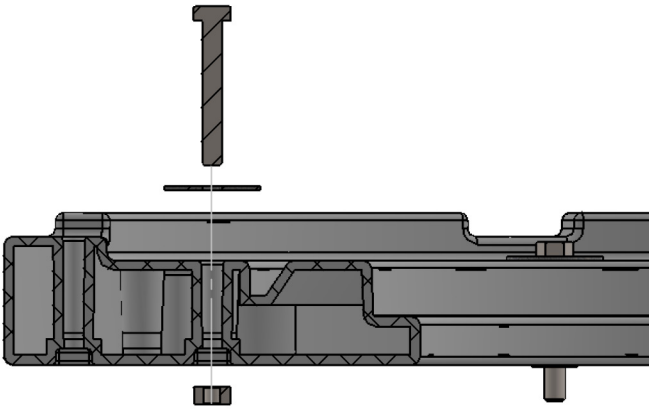

- insert bolt through large washer
- Insert bolt with washer into the hole near the base of the drum so that the washer overlaps the bottom rim of the drum.
- Insert square nuts into the square pocket on the bottom of the dolly.
- Tighten the bolt with a 1/2" wrench. Do not over tighten.

Use optional fiber drum retainer kit shown on front

- Insert bolts first through 5/16" washer, then through hole in Z-Bracket.
- Insert square nut into the pocket on the bottom side of the lug and finger tighten.
- Adjust the Z-Bracket so that it engages the recess above the metal rim on the drums bottom edge.
- Tighten the bolt with a 1/2" wrench. Do not over tighten.